

#013010, 013011

2005 Ford Super Duty 4wd

4", 6" 4-Link Suspension System



READ AND UNDERSTAND ALL INSTRUCTIONS AND WARNINGS PRIOR TO INSTALLATION OF SYSTEM AND OPERATION OF VEHICLE.

SAFETY WARNING

BDS Suspension Co. recommends this system be installed by a professional technician. In addition to these instructions, professional knowledge of disassembly/ reassembly procedures and post installation checks must be known.

PRODUCT SAFETY WARNING

Certain BDS Suspension products are intended to improve off-road performance. Modifying your vehicle for off-road use may result in the vehicle handling differently than a factory equipped vehicle. Extreme care must be used to prevent loss of control or vehicle rollover. Failure to drive your modified vehicle safely may result in serious injury or death. BDS Suspension Co. does not recommend the combined use of suspension lifts, body lifts, or other lifting devices.

You should never operate your modified vehicle under the influence of alcohol or drugs. Always drive your modified vehicle at reduced speeds to ensure your ability to control your vehicle under all driving conditions. Always wear your seat belt.

PRE-INSTALLATION NOTES

1. Special literature required: OE Service Manual for model/year of vehicle. Refer to manual for proper disassembly/reassembly procedures of OE and related components.
2. Adhere to recommendations when replacement fasteners, retainers and keepers are called out in the OE manual.
3. Larger rim and tire combinations may increase leverage on suspension, steering, and related components. When selecting combinations larger than OE, consider the additional stress you could be inducing on the OE and related components.

4. Post suspension system vehicles may experience drive line vibrations. Angles may require tuning, slider on shaft may require replacement, shafts may need to be lengthened or trued, and U-joints may need to be replaced.
5. Secure and properly block vehicle prior to installation of BDS Suspension components. Always wear safety glasses when using power tools.
6. If installation is to be performed without a hoist, BDS Suspension Co. recommends rear alterations first.
7. Due to payload options and initial ride height variances, the amount of lift is a base figure. Final ride height dimensions may vary in accordance to original vehicle attitude. Always measure the attitude prior to beginning installation.

POST-INSTALLATION WARNINGS

1. Check all fasteners for proper torque. Check to ensure for adequate clearance between all rotating, mobile, fixed, and heated members. Verify clearance between exhaust and brake lines, fuel lines, fuel tank, floor boards and wiring harness. Check steering gear for clearance. Test and inspect brake system.
2. Perform steering sweep to ensure front brake hoses have adequate slack and do not contact any rotating, mobile or heated members. Inspect rear brake hoses at full extension for adequate slack. Failure to perform hose check/ replacement may result in component failure. Longer replacement hoses, if needed can be purchased from a local parts supplier.
3. Perform head light check and adjustment.
4. Re-torque all fasteners after 500 miles. Always inspect fasteners and components during routine servicing.

102 S. Michigan Avenue • Coldwater, MI 49036
517-279-2135 • www.bds-suspension.com

PARTS LIST

Part #	Qty	Description
02023	2	Lower 4-Link Arm
02024	2	Upper 4-Link Arm
02026	1	4-Link Frame Bracket (drv)
02027	1	4-Link Frame Bracket (pass)
3527	8	Link Bushing
7-1	4	1.000 x 0.120 x 3.250 Sleeve
60107	4	90 deg grease zerker
432	1	Bolt Pack
422	1	Bolt Pack
431	1	Bolt Pack
02022	1	Track Bar Bracket
02019	2	Cam Washer
02025	2	Sway Bar Drop Bracket
02018	2	Bump Stop Spacer
083404R	1	Pitman Arm
02017	2	Brake Line Bracket
01528	1	Stabilizer Bracket
342701	1	Loctite - 1ml

BOLT PACK 422

Qty	Description
4	3/8"-16 x 1-1/4" bolt grade 8 yellow zinc
4	3/8"-16 prevailing torque nut yellow zinc
8	3/8" USS flat washer thru-hardened yellow zinc

BOLT PACK 431

Qty	Description
2	5/16"-18 x 1-1/4" bolt grade 8 yellow zinc
2	5/16"-18 x 1" bolt grade 8 yellow zinc
4	5/16"-18 prevailing torque nut yellow zinc
8	5/16" SAE flat washer yellow zinc
2	5/16"-18 x 3/4" bolt grade 8 yellow zinc
6	1/4"-20 prevailing torque nut clear zinc
12	1/4" USS flat washer clear zinc
2	1/4"-20 x 3/4" bolt grade 5 clear zinc
4	1/4"-20 x 1" bolt grade 5 clear zinc
1	1/8" x 1" cotter pin clear zinc

BOLT PACK 432

Qty	Description
14	1/2"-13 x 1-1/2" bolt grade 8 yellow zinc
14	1/2"-13 prevailing torque nut yellow zinc
28	1/2" SAE flat washer thru-hardened yellow zinc
4	3/4"-10 x 5-1/2" bolt grade 8 yellow zinc
4	3/4"-10 prevailing torque nut yellow zinc
8	3/4" SAE flat washer thru-hardened yellow zinc
2	Wire Clip (Fastenal #0708762)
2	1/4"-20 x 3/4" bolt grade 5 clear zinc
2	1/4"-20 prevailing torque nut clear zinc
4	1/4" USS flat washer clear zinc

INSTALLATION INSTRUCTIONS

FRONT INSTALLATION

1. Park the vehicle on a clean, flat surface and block the rear wheels for safety.
2. Disconnect the front track bar from the frame mount. Retain hardware.
3. Raise the front of the vehicle and support under the frame rails with jack stands. **Note:** As a result of the location of the long radius arm suspension, support locations are limited. Use your best judgment while supporting the vehicle with sufficient strength stands at appropriate locations. The radius arms will need to move freely during this installation.
4. Remove the front wheels.
5. Support the front axle with a hydraulic jack.
6. Disconnect the front brake lines from the axle and frame (Fig 1). Retain hardware.

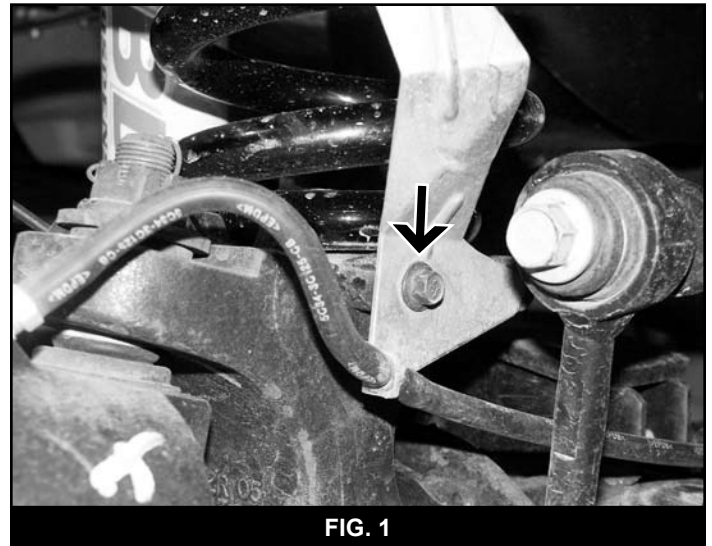

FIG. 1

7. Free the hub vacuum lines from the axle (Fig 2, 3).
8. Disconnect the sway bar end links from the axle mounts. Retain hardware.
9. Remove the OE shock. Retain lower mounting hardware.

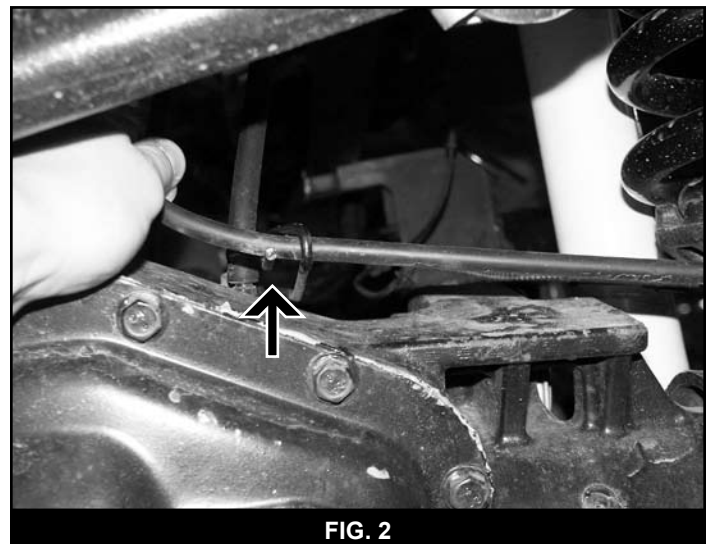
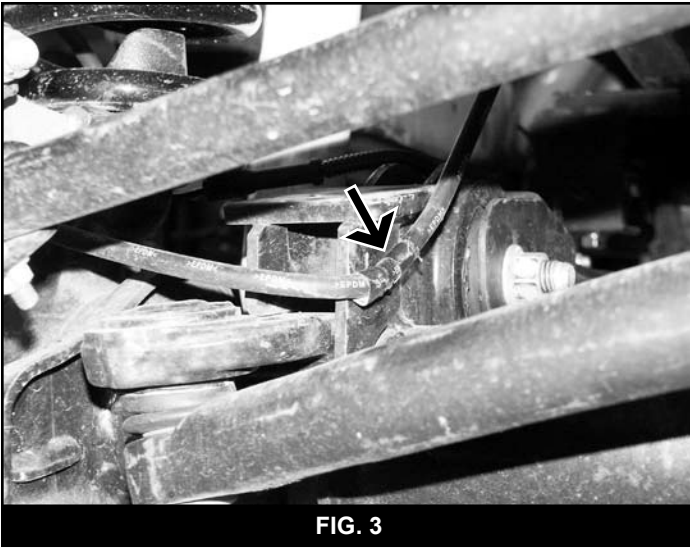
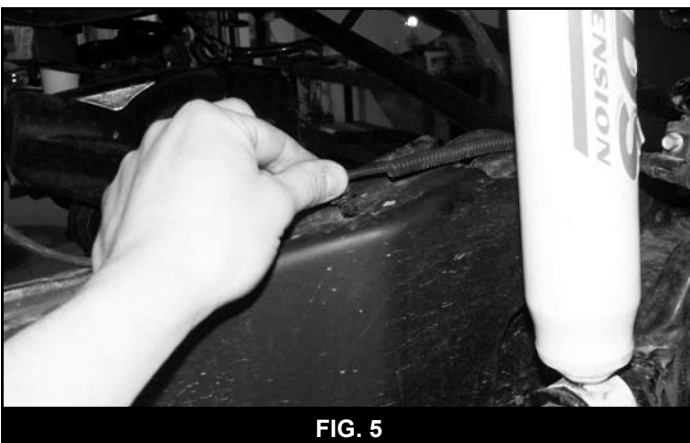
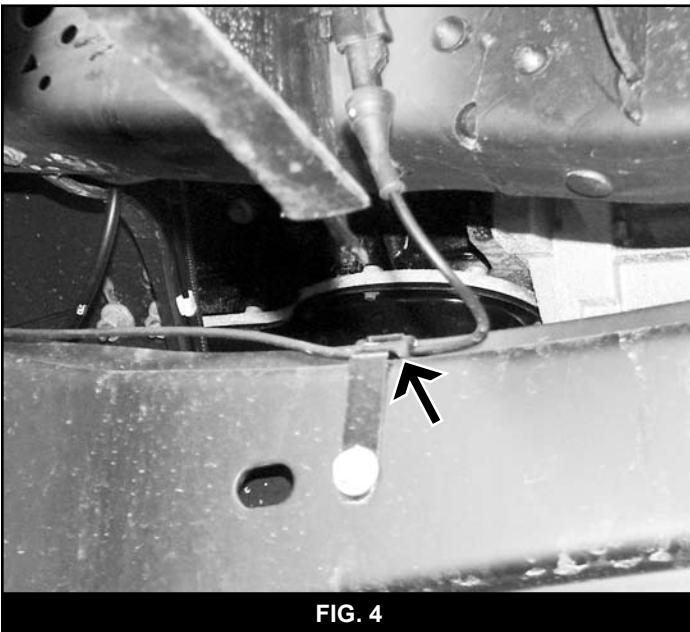

FIG. 2



10. Remove the ABS line from the metal retaining tab on the radius arm (Fig 4). Carefully pull the plastic retaining clip free from the radius arm (Fig 5).



11. Disconnect the OE steering stabilizer from the drag link and the frame mount. Remove the two nuts (and bolt tab) mounting the stabilizer frame mount and remove it from the vehicle. Retain the frame bracket mounting hardware.

12. Install the new steering stabilizer bracket to the frame using the original hardware (Fig 6). Mount the stabilizer bracket to the back side of the frame crossmember in the original mounting holes. Torque hardware to 55 ft-lbs.
13. Install the provided shock stud in the new stabilizer bracket up through the bracket so that the stud points down (Fig 6). Torque to 50 ft-lbs.

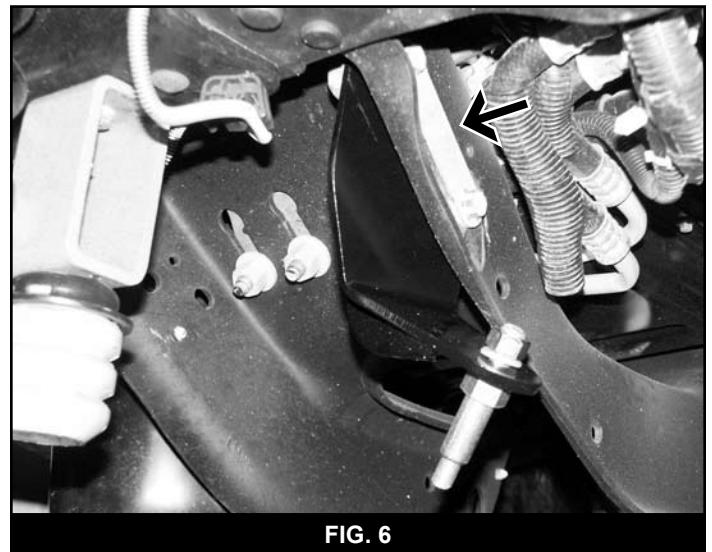

14. Disconnect the (5) bolts mounting the OE track bar bracket to the frame. Remove bracket and retain hardware.
15. Disconnect the drag link from the pitman arm. Retain hardware. Free the drag link from the pitman arm with a pickle fork.
16. Remove the pitman arm nut. Note the indexing of the pitman arm in relation to the steering sector shaft and remove the pitman arm from the steering box using the appropriate puller.
17. Remove all of the dri-lock compound on the threads of the OE nut and steering sector shafts. This is important to ensure that the new thread lock compound will adhere properly.
18. Apply a bead of the supplied thread lock all the way around the threads of the OE nut.
19. Install the new pitman arm (indexed the same as the OE) and fasten with the OE nut. Torque the nut to 350 ft-lbs.
20. Lower the axle until the OE coil springs are free and remove the springs from the vehicle. Retain the upper spring isolator for use with the new springs. **Note: Do not over extend the brake lines.**
21. Install the new track bar bracket using the stock mounting hardware as it was removed (Fig 7). Torque all (5) mounting bolts to 129 ft-lbs.



FIG. 7 (from front)

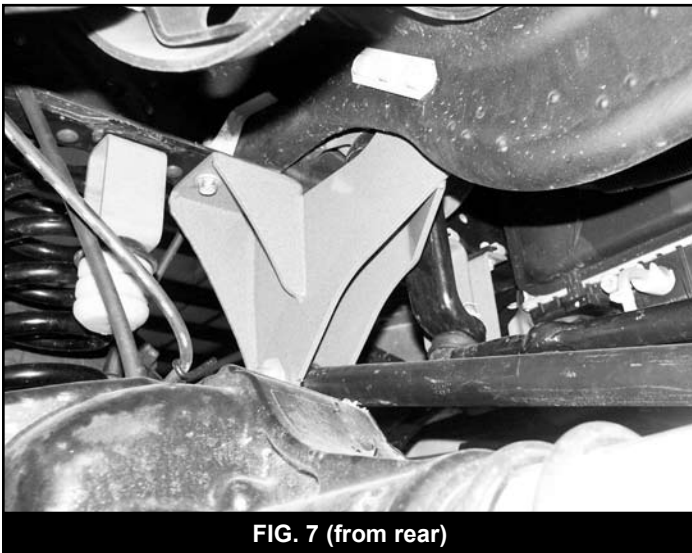

FIG. 7 (from rear)



FIG. 8

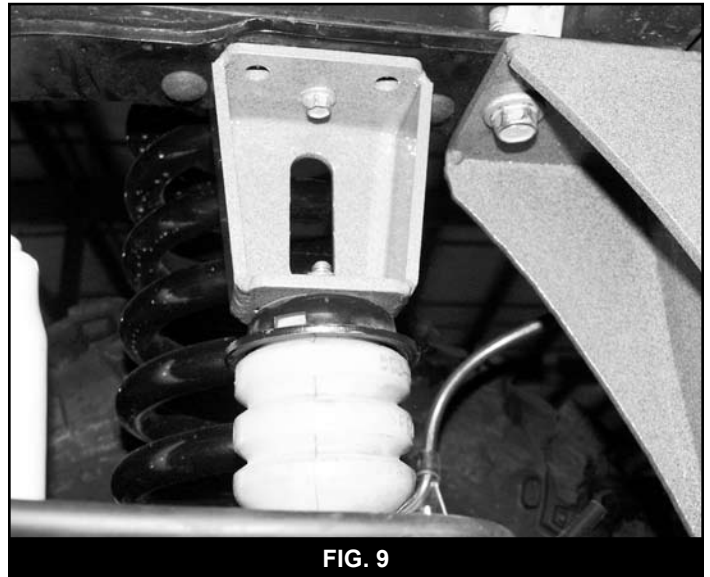

FIG. 9

22. Pull the OE front bump stops free from the bump stop cups and remove the bolt mounting the cup to the frame (Fig 8).
23. Install the cup on the provided bump stop extension with a 5/16" x 1" bolt, nut and 5/16" SAE washers from bolt pack #431. The alignment tab on the bump stop cup will fit in the second hole in the extension. Torque hardware to 20 ft-lbs.
24. Install the extended bump stop to the frame with the original hardware and torque to 20 ft-lbs (Fig 9). The closed face of the extension should face the outside of the vehicle. Install the original bump stop in the relocated bump stop cup.
25. Loosen the four radius arm-to-axle mounting bolts but do not remove. Once again, ensure that the front axle is well supported.
26. Starting with the passenger's side, remove the upper radius arm-to-axle mounting bolt. Remove the radius arm-to-frame bolt as well. This will allow the radius arm to swing down away from the frame. Remove the lower radius arm-to-axle bolt and remove the arm from the vehicle. Retain hardware.
27. Lightly grease and install the provided bushings (3527RB) and sleeves (7-1) in the four new control arms (02023, 02024).

28. Install the provided 90° grease fittings in the threaded holes at the bushing end of the control arms. When installed the fittings should point toward the body of the control arm. (Fig. 10)

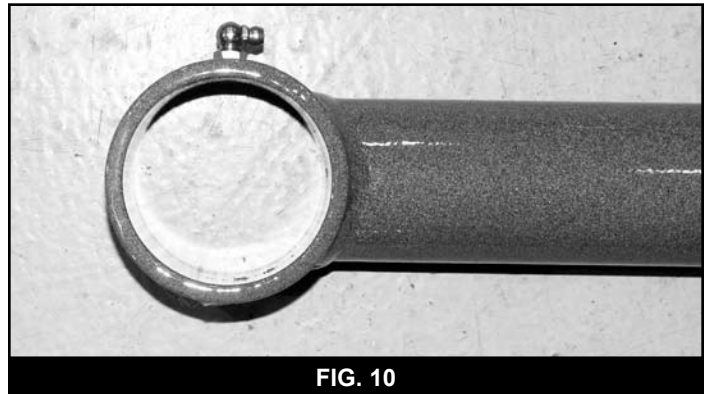
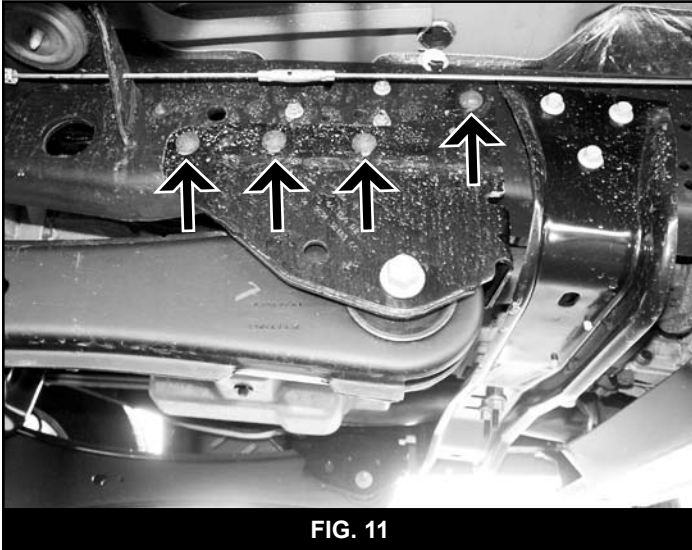
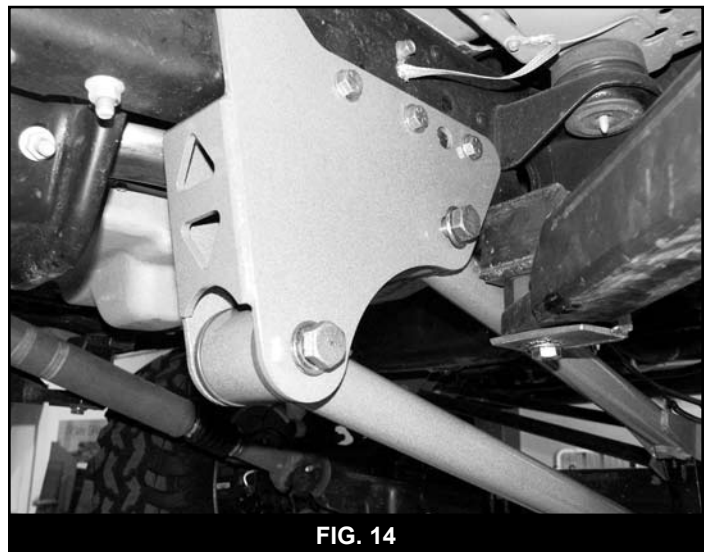
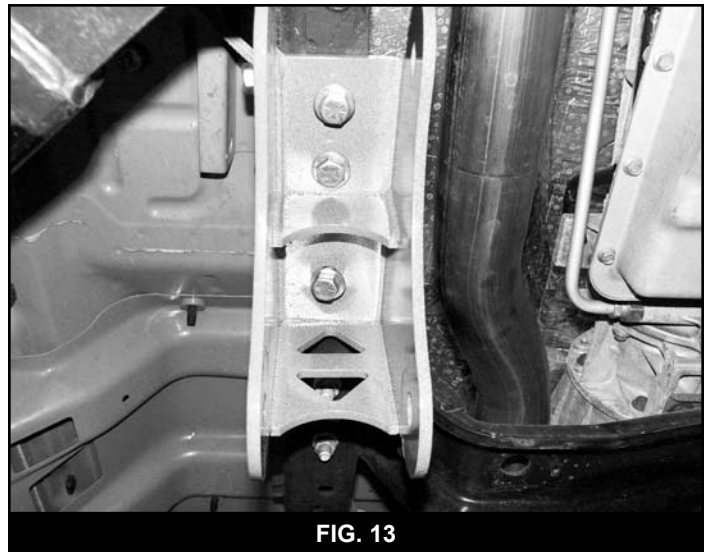
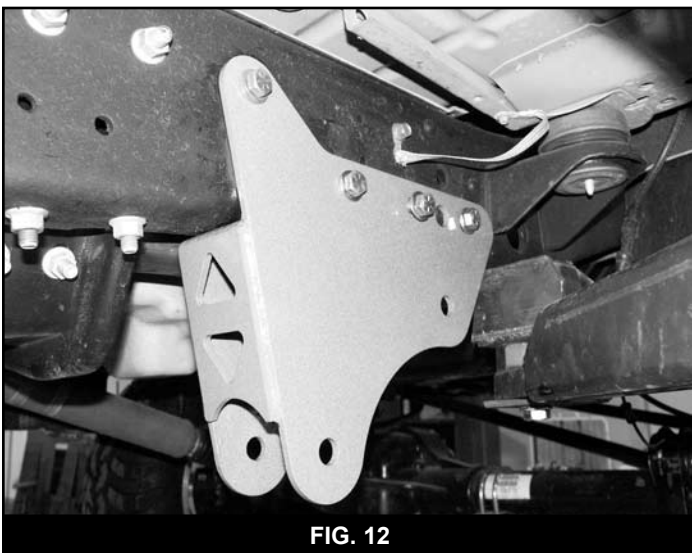

FIG. 10

29. Locate the seven rivets that attach the OE radius arm mounting bracket to the frame. There will be four on the outside and three in the inside of the bracket fastening the bracket to the bottom of the frame. (Fig. 11)



30. Remove the seven rivets with a grinder, drill, air chisel or combination of these tools. Do not use a torch. The undercoating used on the frame is highly flammable. Also, the fuel system lines run inside of the driver's side frame rail.
31. With the rivets removed, free the radius arm bracket from the frame. Ensure that all of the rivets are removed from the holes in the frame.
32. Place the new passenger's side 4-Link bracket (02027) up to the frame and align the existing rivet holes with the corresponding holes in the bracket. Attach the bracket with $\frac{1}{2}$ " x 1-1/2" bolts, nuts and $\frac{1}{2}$ " SAE flat washers from bolt pack #432. Torque $\frac{1}{2}$ " hardware to 90 ft-lbs. (Fig. 12, 13)
33. Install the assembled upper control arm in the new frame bracket and fasten with a $\frac{3}{4}$ " x 5-1/2" bolt, nut and $\frac{3}{4}$ " SAE flat washers from bolt pack #432. The two tabs on the control arm go up. Leave hardware loose. (Fig. 14)



34. Attach the axle end of the control arm with the original hardware. Leave hardware loose. (Fig. 15)

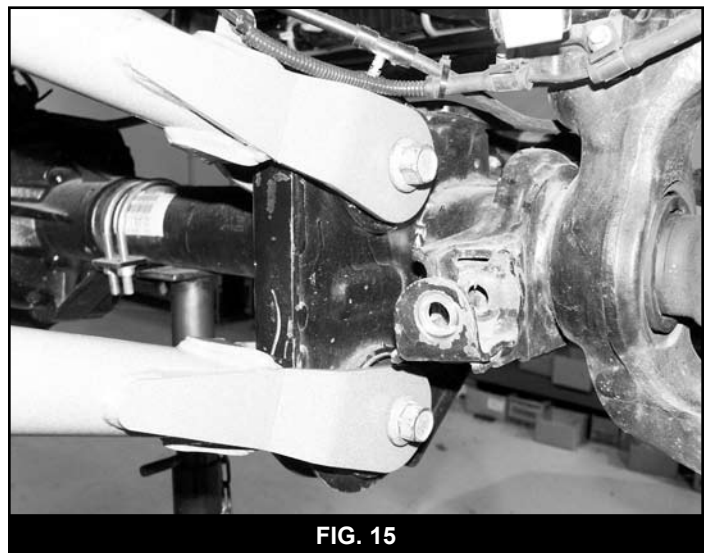

35. Install the new lower control arm in the new frame bracket with a $\frac{3}{4}$ " x 5-1/2" bolt, nut and $\frac{3}{4}$ " SAE flat washers. Install arm so that the grease fitting is up. Leave hardware loose.

36. With the axle well supported, disconnect the driver's side radius arm from the axle. Retain hardware.
37. Attach the new passenger's side lower control arm to the axle with the original hardware. Leave hardware loose.
38. Repeat the frame bracket and control arm procedure on the driver's side of the vehicle. **Notes:** *To help in accessing the bracket bolts, the fuel junction block mounted to the inside of the driver's side frame rail can be disconnected and repositioned out of the way. Use the nut that was removed from the radius arm-to-frame bolt for the upper control arm-to-axle mount bolt on the driver's side. The OE bolt in this position is welded to the radius arm.* (Fig. 16, 17)

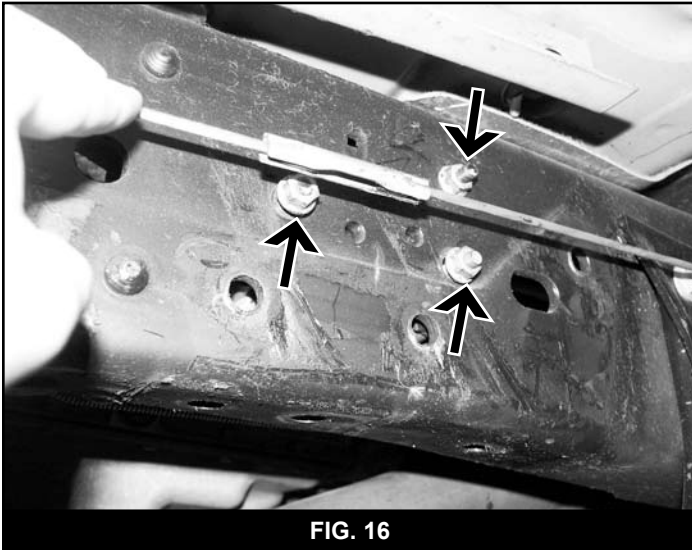

FIG. 16

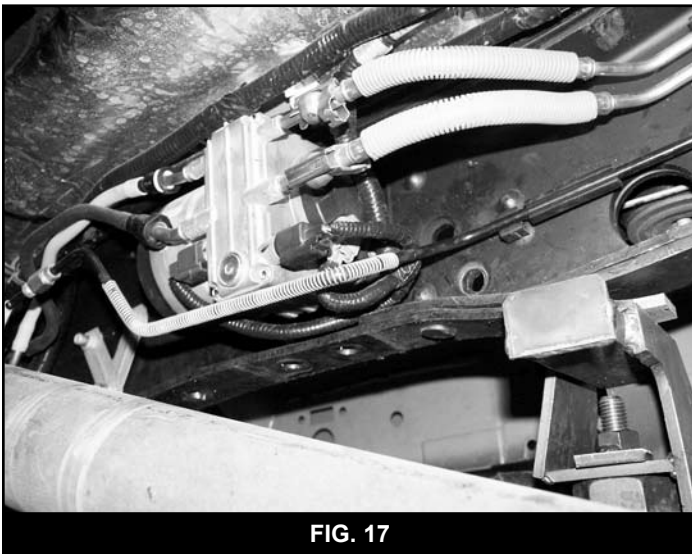

FIG. 17

39. With all of the control arms attached, reinstall the fuel junction block (if removed) on the driver's side frame rail. Torque hardware to 20 ft-lbs.
40. Install the new coil springs in conjunction with the OE top isolator. Rotate the springs so that they seat in the bottom coil perch properly.
41. Install the new shocks using the original lower mounting hardware and the provided upper mounting hardware. Torque the lower bolt to 100 ft-lbs and the upper until the bushings begin to swell.

42. Note the orientation of the front sway bar (top versus bottom). Disconnect the sway bar from the frame and remove from the vehicle. Retain hardware.
43. Install the provided sway bar drop bracket to the original sway bar frame mounting locations with the original hardware. Torque hardware to 30 ft-lbs. **Note:** *The square alignment tabs mount down toward the sway bar.*
44. Attach the sway bar to the new drop brackets in the correct orientation with the 3/8" hardware from bolt pack #422. Torque hardware to 30 ft-lbs (Fig 18).

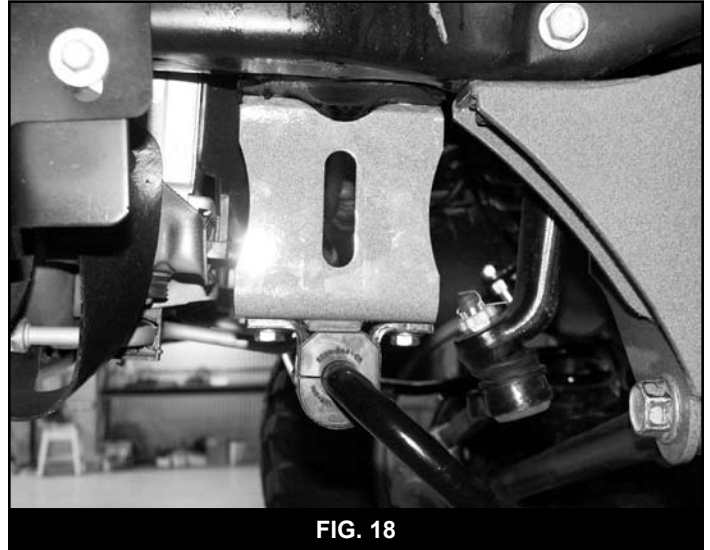

FIG. 18

45. Install the sway bar link ends in the original axle mounts and secure with the OE hardware.
46. Attach the plastic ABS wire clip to the front tab on the new upper control arm. Secure the wire to the rear tab with the provided wire clip and 1/4" x 3/4" blot, nut and 1/4" USS washers. Torque 1/4" hardware to 10 ft-lbs. (Fig. 19)

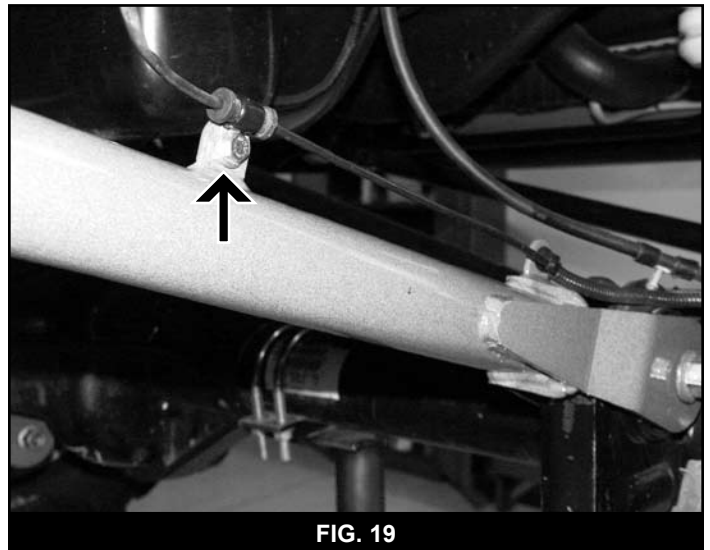

FIG. 19

4" Brake Line Drop

47. Install the provided brake line relocation bracket to the original mounting hole on the coil spring bucket with the OE bolt. (Fig. 20a)

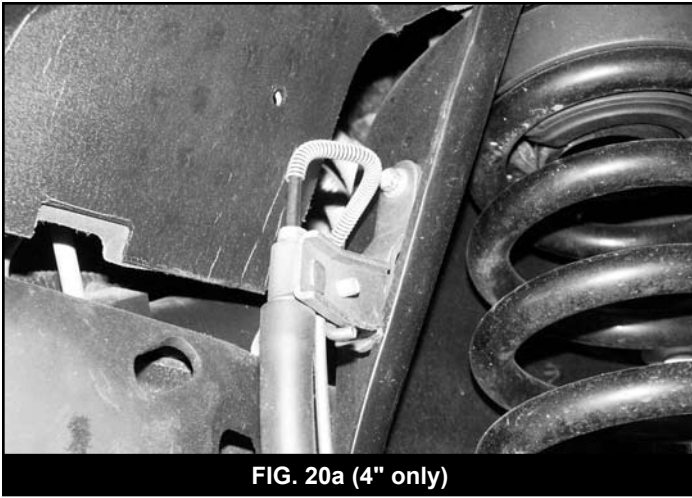

FIG. 20a (4" only)

48. Attach the brake line to the stud on the bracket and secure with a 1/4" nut and 1/4" USS washer from bolt pack #431. Torque OE bolt to 20 ft-lbs and 1/4" nut to 10 ft-lbs.

6" Brake Line Drop

49. Attach the short end of the brake line bracket to the coil mount. (Fig 20b) Align the two holes in the bracket with the existing coil mount holes. Install a 1/4" x 1" bolt, nut and 1/4" USS washers (Bolt Pack #431) in the top hole and the original bolt in the second hole down. Tighten hardware to 10 ft-lbs.



FIG. 20b (6" only)

50. Carefully reform the hard brake line in order to mount it to the lower holes in the bracket. Attach with 1/4" x 1" bolt, nut and 1/4" USS washers (Bolt Pack #431). Tighten to 10 ft-lbs.
51. Reattach the hub vacuum lines to the original locations. **6" Notes:** Reform the driver's side vacuum line retainer on the differential as necessary. Use the provided zip ties to reattach the passenger's side line as necessary.
52. Attach the drag link to the new pitman arm, fasten with the OE nut, and torque to 148 ft-lbs. Install the OE castellated nut cap and new cotter pin (BP #431).
53. Install the tapered steering stabilizer stud in the original tapered mounting hole in the drag link. Torque hardware to 55 ft-lbs.

54. Install the new steering stabilizer cylinder to the stud on the frame bracket the new stud in the drag link. Torque hardware to 45 ft-lbs.
55. Install the wheels and lower the vehicle to the ground.
56. Attach the track bar to the new bracket with the OE hardware. Turn the steering wheels to aid in aligning the track bar in the bracket. Torque hardware to 406 ft-lbs. Install the provided cam washers between the alignment tabs on the bracket. If installing a 4" lift, the cams will offset closer to the driver's side. They will offset to the passenger's side for a 6" lift. (Fig. 21)

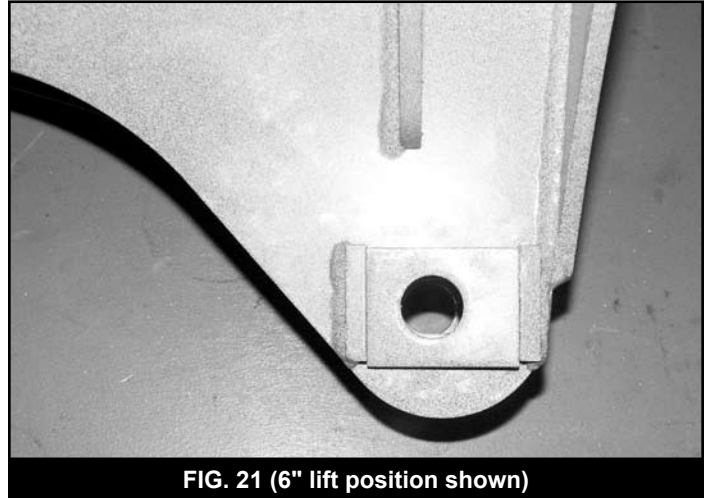

FIG. 21 (6" lift position shown)

57. Torque all eight control arm bolts to 250 ft-lbs.

REAR INSTALLATION

58. Raise the rear of the vehicle and support with jack stands under the frame rails just ahead of the spring hangers.
59. Remove the wheels.
60. Support the axle with a hydraulic jack.
61. Remove the OE shocks. Retain all mounting hardware.

Block Kit Only (4" only)

62. Disconnect the passenger's side spring u-bolts.
63. Lower the axle enough to place the provided 3" lift block between the axle and OE block.
64. Ensure that the mounting surfaces are clean of dirt and corrosion and install the new block so that the short end is toward the front. Also make certain that the OE block is on top of the new block and that the bump stop wing is pointing inward.
65. Raise the axle to engage all of the block/spring alignment pins. Fasten the entire assembly with the provided u-bolts, high nuts and washers. Snug but do not torque the u-bolts at this time.
66. Repeat block installation of the driver's side. Take care not to over extend the brake lines. **Note:** You may disconnect the parking brake mounting tab on the spring plate before removing the u-bolts and reattach after the installation is complete.

Leaf Spring Kit Only

67. Disconnect the passenger's side u-bolts and lower the axle from the spring.
4" Kit: Remove the OE block, it will not be reused.
6" Kit: Retain OE block to be installed with new spring.
68. Loosen and remove the front spring-to-frame and rear shackle-to-frame bolts and remove the spring from the vehicle.
69. Remove the shackle from the OE spring and loosely install it on the new rear spring. Be sure that the shackle is oriented on the new spring identical to the old. The shackles mount of the longer end of the spring (opposite of the end marked with "FRT").
70. Install the new spring in the vehicle with the OE bolts. Leave hardware loose. All of the spring pivot bolts will be torqued with the weight of the vehicle on the springs.
71. Remove all dirt and corrosion from the axle spring pad and raise the axle to the spring while aligning the center pin with the center pin hole. Fasten the spring with the provided u-bolts. Snug but do not torque u-bolts at this time.
72. Repeat the procedure on the driver's side. Disconnect the parking brake cable bracket from the spring plate and retain hardware (Fig 22). Take care not to over extend the brake lines.



FIG. 22

73. Reattach parking brake cable bracket to the spring plate. If more slack is needed remove the cable from the rear-most cable ring on the frame rail (Fig 23).



FIG. 23

Block and Leaf Springs Kits

74. Install the new shocks with the original mounting hardware. **Note:** With the shocks installed, allow the axle to hang at full droop. Check shock to shock mount u-bolt clearance. In some cases, the shock may contact the u-bolt. If this is the case, loosen the u-bolt and rotate the mount up, moving the shock away from the axle tube. Retighten the u-bolts to 90 ft-lbs. The bracket can also be tack welded in place to prevent any movement, but is not necessary.
75. Install wheels and lower the vehicle to the ground.
76. With the weight of the vehicle on the axle, torque the u-bolts to 130-150 ft-lbs.
77. Leaf spring to front spring hanger torque bolts to 222 ft.lbs.
78. Leaf spring to shackle and shackle to frame mount torque bolts to 185 ft.lbs.
79. Check all hardware for proper torque.
80. Adjust steering wheel.
81. Adjust headlights
82. Check hardware after 500 miles.

**#013318, 013319, 013418,
013419, 013518, 013519**

2005 Ford Super Duty 4wd

3", 4", 5" Rear Block Kit



**READ AND UNDERSTAND ALL INSTRUCTIONS AND WARNINGS PRIOR
TO INSTALLATION OF SYSTEM AND OPERATION OF VEHICLE.**

INSTALLATION INSTRUCTIONS

1. Park the vehicle on a clean, flat surface and block the front wheels for safety.
2. Raise the rear of the vehicle and support with jack stands under the frame rails just ahead of the spring hangers.
3. Remove the wheels.
4. Support the axle with a hydraulic jack.
5. Remove the OE shocks. Retain all mounting hardware.
6. Disconnect the passenger's side spring u-bolts.
7. Lower the axle enough to place the provided 3" or 4" lift block between the axle and OE block. If installing the 5" block, then you must remove the OE block.
8. Ensure that the mounting surfaces are clean of dirt and corrosion and install the new block so that the short end is toward the front. Also make certain that the OE block is on top of the new block and that the bump stop wing is pointing inward.
9. Raise the axle to engage all of the block/spring alignment pins. Fasten the entire assembly with the provided u-bolts, high nuts and washers. Snug but do not torque the u-bolts at this time.
10. Repeat block installation of the driver's side. Take care not to over extend the brake lines. Note: You may disconnect the parking brake mounting tab on the spring plate before removing the u-bolts and reattach after the installation is complete.
11. Install the new shocks with the original mounting hardware. Note: With the shocks installed, allow the axle to hang at full droop. Check shock to shock mount u-bolt clearance. In some cases the shock may contact the u-bolt. If this is the case, loosen the u-bolt and rotate the mount up, moving the shock away from the axle tube. Retighten the u-bolts to 90 ft-lbs. The bracket can also be tack welded in place to prevent any movement, but is not necessary.
12. Install wheels and lower the vehicle to the ground.
13. With the weight of the vehicle on the axle torque the u-bolts to 130-150 ft-lbs.
14. Check all hardware for proper torque.
15. Check hardware after 500 miles.

**102 S. Michigan Avenue • Coldwater, MI 49036
517-279-2135 • www.bds-suspension.com**

Shock Absorber Installation Instructions



READ AND UNDERSTAND ALL INSTRUCTIONS AND WARNINGS PRIOR TO INSTALLATION OF SYSTEM AND OPERATION OF VEHICLE.

LIMITED LIFETIME WARRANTY

BDS Suspension Co. warrants to the original retail purchaser that its shock and stabilizer cylinders are free from defects in material and workmanship for so long as they own the vehicle. Excluded from this warranty are the finish of the product and mounting bushings. Defects in material and workmanship do not include such things as dented cylinders or bent rods caused by obvious side impact, rust, worn or deformed bushings. A shock absorber is a wear item and over time will experience diminished damping resistance due to normal component wear. This is not a defect in material or workmanship and is therefore not warrantable.

BDS Suspension's obligation under all warranties is limited to the repair or replacement, at BDS's option, of the defective material. Any cost of removal, installation or reinstallation, freight charges, incidental or consequential damages are expressly excluded from these warranties.

INSTALLATION INSTRUCTIONS

1. **Note: Please read instructions thoroughly before installing shock absorber.**
2. Remove old shock absorber from vehicle. Note any spacers, washers, sleeves or other hardware and note their location. Compare the existing hardware with the supplied hardware. Always use new hardware wherever possible. Due to the variety of applications, you may not use any or all of the hardware supplied. You may need to use some of the original hardware. If any of the original hardware is damaged, corroded, bent or broken it must be replaced.

3. If installing dust boot, do so at this time. **Note: The use of a lubricant like dish soap on the inside of the boot will ease installation.** Make sure the washer at the top of the shock is fully seated in the boot all the way around. Secure the bottom of the boot to the cylinder with a plastic tie strap.
4. Install any required bushings and sleeves in to the shock eyes at this time. Install the shock absorber on the vehicle. Use the appropriate illustration as a frame of reference. Due to the different shock mounts within a vehicle model range, the shock eyes must be built to match the shocks that you removed by using the universal hardware kit included. Choose the sleeve with an I.D. closest to the O.D. of the mounting stud or bolt without binding. Some applications will require some extra effort to install.
5. Check all fasteners for tightness before driving and inspect periodically.

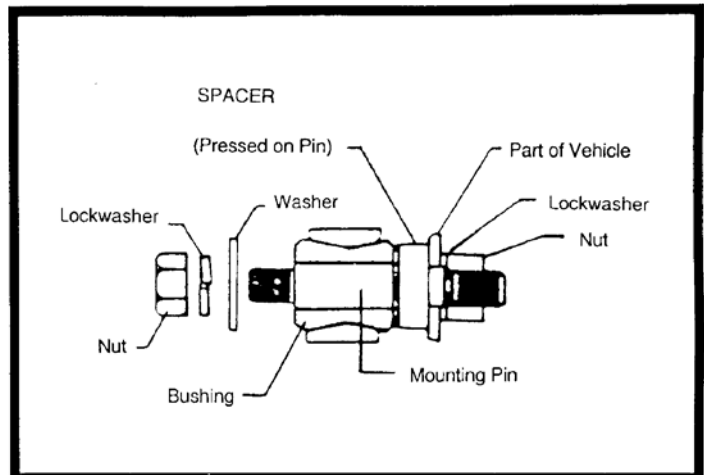

102 S. Michigan Avenue • Coldwater, MI 49036
517-279-2135 • www.bds-suspension.com

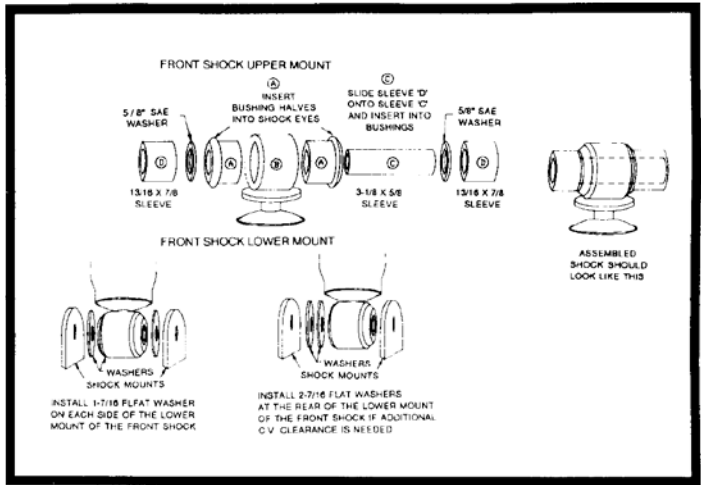
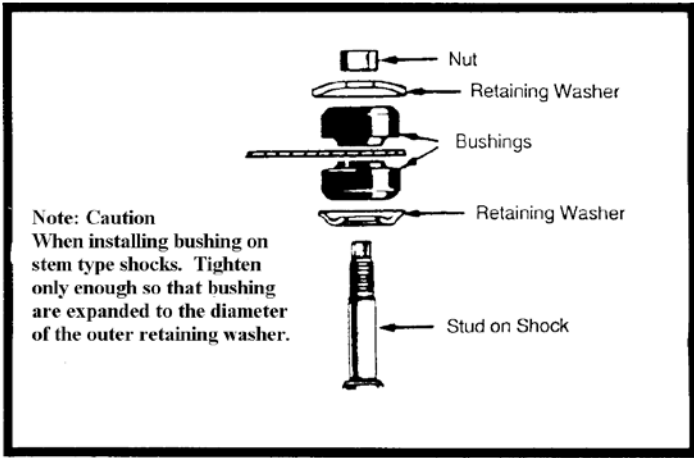

CHEV. S-SERIES W/LIFT

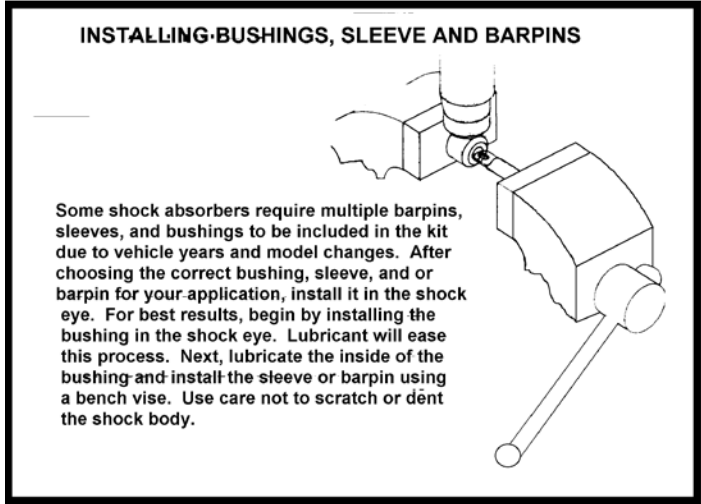
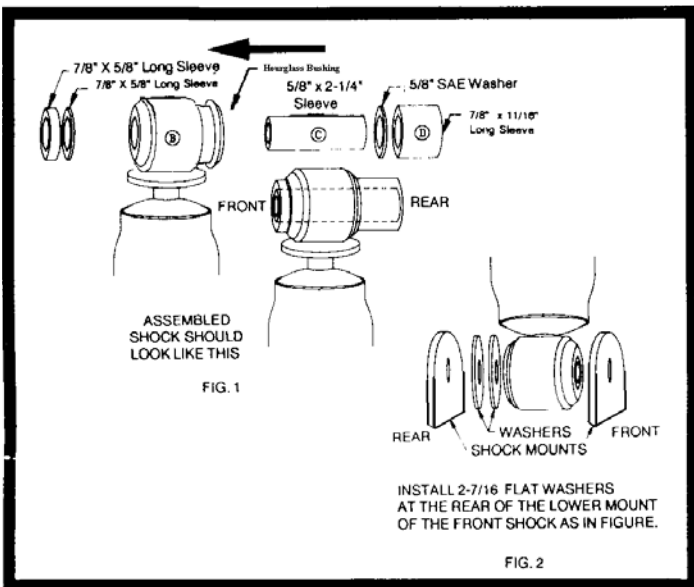
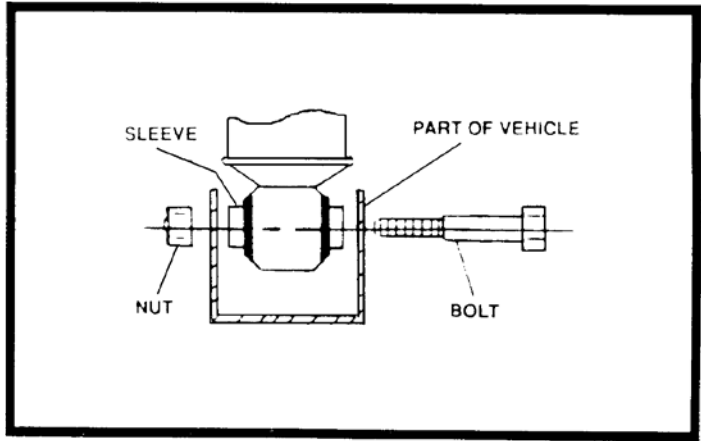
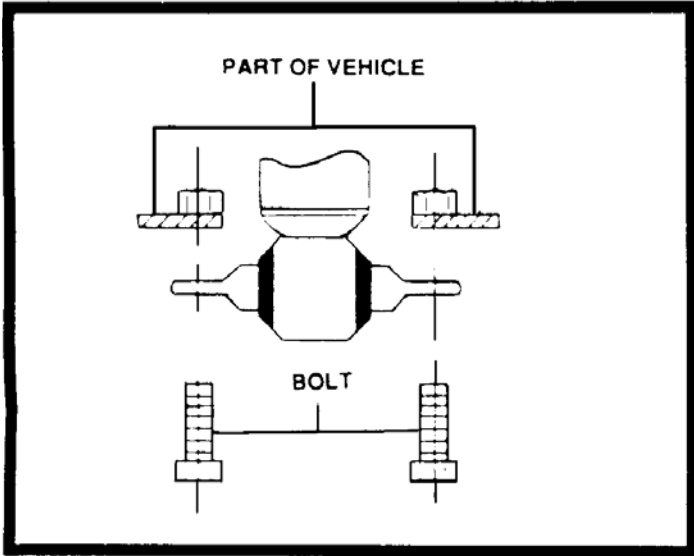

FULL-SIZE CHEV. W/LIFT 88-UP MODELS