

**#034204, 034211, 034206,  
034208, 114202**

**2" Suspension System**

**Jeep TJ, XJ, ZJ**



**READ AND UNDERSTAND ALL INSTRUCTIONS AND WARNINGS PRIOR  
TO INSTALLATION OF SYSTEM AND OPERATION OF VEHICLE.**

### **SAFETY WARNING**

BDS Suspension Co. recommends this system be installed by a professional technician. In addition to these instructions, professional knowledge of disassembly/ reassembly procedures and post installation checks must be known.

### **PRODUCT SAFETY WARNING**

Certain BDS Suspension products are intended to improve off-road performance. Modifying your vehicle for off-road use may result in the vehicle handling differently than a factory equipped vehicle. Extreme care must be used to prevent loss of control or vehicle rollover. Failure to drive your modified vehicle safely may result in serious injury or death. BDS Suspension Co. does not recommend the combined use of suspension lifts, body lifts, or other lifting devices.

You should never operate your modified vehicle under the influence of alcohol or drugs. Always drive your modified vehicle at reduced speeds to ensure your ability to control your vehicle under all driving conditions. Always wear your seat belt.

### **PRE-INSTALLATION NOTES**

1. Special literature required: OE Service Manual for model/year of vehicle. Refer to manual for proper disassembly/reassembly procedures of OE and related components.
2. Adhere to recommendations when replacement fasteners, retainers and keepers are called out in the OE manual.
3. Larger rim and tire combinations may increase leverage on suspension, steering, and related components. When selecting combinations larger than OE, consider the additional stress you could be inducing on the OE and related components.

4. Post suspension system vehicles may experience drive line vibrations. Angles may require tuning, slider on shaft may require replacement, shafts may need to be lengthened or trued, and U-joints may need to be replaced.
5. Secure and properly block vehicle prior to installation of BDS Suspension components. Always wear safety glasses when using power tools.
6. If installation is to be performed without a hoist, BDS Suspension Co. recommends rear alterations first.
7. Due to payload options and initial ride height variances, the amount of lift is a base figure. Final ride height dimensions may vary in accordance to original vehicle attitude. Always measure the attitude prior to beginning installation.

### **POST-INSTALLATION WARNINGS**

1. Check all fasteners for proper torque. Check to ensure for adequate clearance between all rotating, mobile, fixed, and heated members. Verify clearance between exhaust and brake lines, fuel lines, fuel tank, floor boards and wiring harness. Check steering gear for clearance. Test and inspect brake system.
2. Perform steering sweep to ensure front brake hoses have adequate slack and do not contact any rotating, mobile or heated members. Inspect rear brake hoses at full extension for adequate slack. Failure to perform hose check/ replacement may result in component failure. Longer replacement hoses, if needed can be purchased from a local parts supplier.
3. Perform head light check and adjustment.
4. Re-torque all fasteners after 500 miles. Always inspect fasteners and components during routine servicing.

**102 S. Michigan Avenue • Coldwater, MI 49036  
517-279-2135 • www.bds-suspension.com**

## Parts List

Part #	Qty	Description
034204	2	Coils
034206	2	Coils
034211	2	Coils
034208	2	Coils
	1	01314 Track Bar Bracket
	1	6-1 Sleeve
	1	12mm-1.75x 70 mm Bolt grade 10.9
	1	12mm-1.75 Prevailing Torque Nut
	2	7/16" USS Flat Washer
	2	7/16"-14 x 1-1/4" Bolt grade 5
	2	7/16"-14 Prevailing Torque Nut
	4	7/16" SAE Flat Washers
114202	2	Add-A-Leafs
	2	3/8" x 4.5" Center Pins & Nuts
	2	5/16" x 3.5" Center Pins & Nuts
	4	2-1/2" Spring Clamp Clips
124209	1	Track Bar Bracket
	1	7/8" x 0.156 x 1.600 Sleeve
	1	Bolt Pack
	1	12mm-1.75 x 70mm bolt grade 10.9 clear zinc
	1	12mm-1.75 prevailing torque nut clear zinc
	2	7/16" USS flat washer clear zinc
	2	7/16"-14 x 1-1/4" bolt grade 5 clear zinc
	2	7/16"-14 prevailing torque nut clear zinc
	4	7/16" SAE flat washer clear zinc

## Pre-Installation Notes

CHEROKEE XJ ONLY: Before installing this suspension system check for the correct sized rear U-bolts. The XJ came equipped with three different axles from the factory. The following is a list of the axle options and the U-bolts required. If axle type is not known measure the OD of the axle tube.

**Chrysler type rear axle – 3-1/8 OD, BDS #040012**

**Dana 35 – 2-3/4 OD, BDS #040005**

## Front System Installation

1. Raise and support the vehicle. Place a hydraulic jack under the axle to support it.
2. Paint or scribe alignment marks on the cam adjuster and axle bracket. (Fig 1)
3. Remove the lower control arm nut, cam, and cam bolts from the axle. (Fig 2)
4. Disconnect the stabilizer bar links from the axle
5. Remove the shocks.

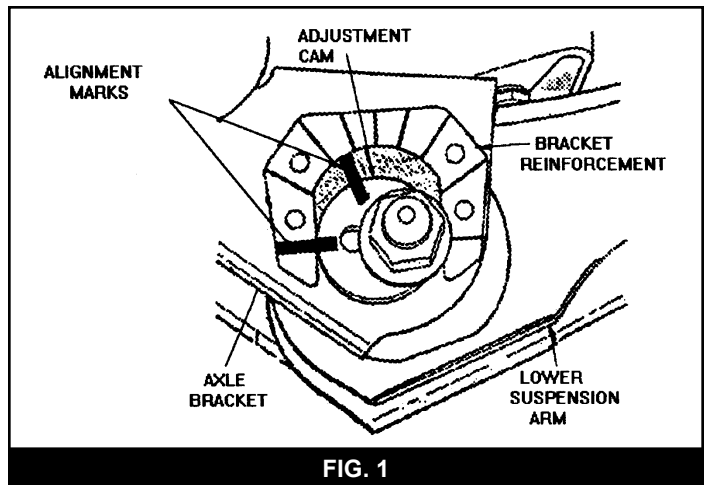

FIG. 1

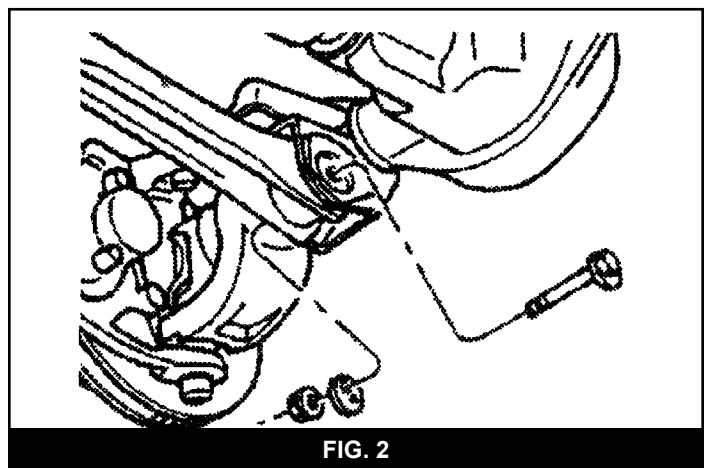

FIG. 2

6. Disconnect the track bar from the frame rail bracket. Remove the cotter pin. Remove the nut. Use a universal puller tool to separate the ball stud from the bracket.
7. Disconnect the drag link from the pitman arm by removing the cotter pin and nut.
8. Remove the drag link ball stud from the pitman arm using a puller.
9. Remove O.E. coil springs.
10. Install the BDS coil spring. Be sure to center the spring before tightening the retainer. Raise the axle to bring the spring in to contact with both the upper and lower mounts, but do not place the spring under compression, before tightening the retainer. **Note: Take care not to stretch the brakelines.**
11. Connect the stabilizer bar links. Torque to 70 ft. lbs.
12. Install the BDS shocks at this time.
13. Connect the track bar to the frame rail. Note: It may be necessary to pry the axle assembly over in order to install the track bar. Install the ball stud into the frame rail bracket. Install the retaining nut on the stud. Torque to 65 lbs. Install new cotter pin. **Note: Always tighten the nut in order to align the cotter pin hole, never loosen.**
14. Position the lower suspension arm in the axle bracket.
15. Install cam bolts, cam, and nut. Finger tighten only, do not tighten at this time.

16. Install the drag link ball stud into the pitman arm. Install the nut & torque to 60 lbs. Install a new cotter pin as described previously.
17. Remove the supports and lower the vehicle to the ground.
18. Torque the lower control arm pivots at the axle. Align the marks you painted or scribed and torque to 85 lbs.

## Rear System Installation (TJ & ZJ Only)

19. Raise and support the vehicle. Place a hydraulic jack under the axle to support it.
20. Disconnect the stabilizer bar links from the axle. Remove the shock absorbers. Disconnect the track bar from the frame rail bracket. Remove the bolt and nut from the frame rail bracket. Lower the axle until the spring is free from its upper mount. Remove the spring retainer. Remove the coil spring from the vehicle.
21. **ZJ models only:**

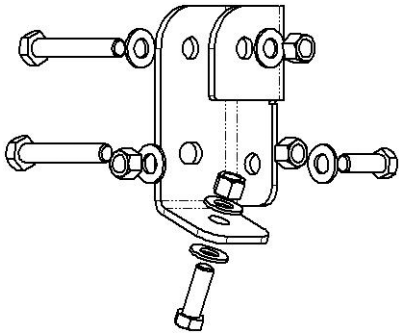

- a) Remove the track bar-to-axle mounting bolt at the driver's side of the axle.
- b) Remove and discard the plastic axle mount cover.
- c) Position the provided track bar bracket on the axle mount and temporarily hold in place with the OE hardware. Using the bracket as a template, mark the bottom and driver's side lower mounting hole positions to be drilled.
- d) Remove the bracket and drill a 1/2" hole at the two marks.
- e) Reinstall the bracket and fasten with the OE hardware through the original location in conjunction with the provided 7/8" x 1.600" spacer sleeve mounted inside of the OE bracket. Leave hardware loose.
- f) Install the provided 7/16" x 1-1/4" bolts, nuts, and washers in the two holes that were drilled. Leave loose.
- g) With the three mounting bolts installed, torque the 7/16" hardware to 45 ft-lbs and the 12mm hardware to 74 ft-lbs.
- h) Install the track bar in the new bracket and fasten with the provided 12mm x 70mm bolt, nut and washers. Leave loose.

22. Install the BDS coil spring. Be sure to center the spring before tightening the retainer. Raise the axle to bring the spring in to contact with both the upper and lower mounts, but do not place the spring under compression, before tightening the retainer. Note: Take care not to stretch the brake-lines. Connect the Stabilizer bar links and torque to 40 lbs.

23. Install BDS shocks at this time.
24. Remove the supports and lower the vehicle.
25. Connect the track bar to the frame rail bracket. **Note:** *It may be necessary to pry the axle assembly over to install the track bar.* Loosely install nut and bolt. Do not tighten at this time.
26. Torque all remaining fasteners.
27. Torque lower shock mounts to 74 lbs
28. Torque the track bar to 74 lbs

## Rear System Installation (XJ Only)

29. Place a floor jack under the axle for support. *Complete the following one side at a time.*
30. Disconnect the stabilizer bar links from the axle brackets, if equipped.
31. Remove the OE shocks.
32. Remove the U-bolts. Lower the axle from the spring.
33. Use C-clamps to hold the spring pack together.
34. Remove the leaf spring center pin and slowly remove the clamps.
35. Place the add-a-leaf between the second and third leaf. Place the rest of the leaves below the add-a-leaf.
36. Slide the new center pin up through the leaf pack and start the nut to hold the pack together. Do not draw the leaf pack together with the center pin. Use a C-clamp on each side of the center pin to draw the pack together while ensuring that the leaves are in line. After the pack is drawn together tighten the center pin.
37. Raise the axle to the spring taking care to align the spring center pin with the hole in the spring perch. Install the new U-bolts, nuts and washers. Torque the U-bolts to 70-85 ft-lbs.
38. Install the new shocks with the OE hardware and torque to manufacturer's specifications.
39. Reattach the stabilizer bar links to the axle brackets.
40. Lower the vehicle to the ground.

## Post-Installation (All Models)

41. Install warning label in a highly visible location inside the cab of the vehicle.
42. Check all fasteners for proper torque.
43. The vehicle will need a front end alignment check.
44. Align headlights.
45. Check all fasteners after 500 miles.

# Shock Absorber Installation Instructions



**READ AND UNDERSTAND ALL INSTRUCTIONS AND WARNINGS PRIOR TO INSTALLATION OF SYSTEM AND OPERATION OF VEHICLE.**

## LIMITED LIFETIME WARRANTY

BDS Suspension Co. warrants to the original retail purchaser that its shock and stabilizer cylinders are free from defects in material and workmanship for so long as they own the vehicle. Excluded from this warranty are the finish of the product and mounting bushings. Defects in material and workmanship do not include such things as dented cylinders or bent rods caused by obvious side impact, rust, worn or deformed bushings. A shock absorber is a wear item and over time will experience diminished damping resistance due to normal component wear. This is not a defect in material or workmanship and is therefore not warrantable.

BDS Suspension's obligation under all warranties is limited to the repair or replacement, at BDS's option, of the defective material. Any cost of removal, installation or reinstallation, freight charges, incidental or consequential damages are expressly excluded from these warranties.

## INSTALLATION INSTRUCTIONS

1. **Note: Please read instructions thoroughly before installing shock absorber.**
2. Remove old shock absorber from vehicle. Note any spacers, washers, sleeves or other hardware and note their location. Compare the existing hardware with the supplied hardware. Always use new hardware wherever possible. Due to the variety of applications, you may not use any or all of the hardware supplied. You may need to use some of the original hardware. If any of the original hardware is damaged, corroded, bent or broken it must be replaced.

3. If installing dust boot, do so at this time. **Note: The use of a lubricant like dish soap on the inside of the boot will ease installation.** Make sure the washer at the top of the shock is fully seated in the boot all the way around. Secure the bottom of the boot to the cylinder with a plastic tie strap.
4. Install any required bushings and sleeves in to the shock eyes at this time. Install the shock absorber on the vehicle. Use the appropriate illustration as a frame of reference. Due to the different shock mounts within a vehicle model range, the shock eyes must be built to match the shocks that you removed by using the universal hardware kit included. Choose the sleeve with an I.D. closest to the O.D. of the mounting stud or bolt without binding. Some applications will require some extra effort to install.
5. Check all fasteners for tightness before driving and inspect periodically.

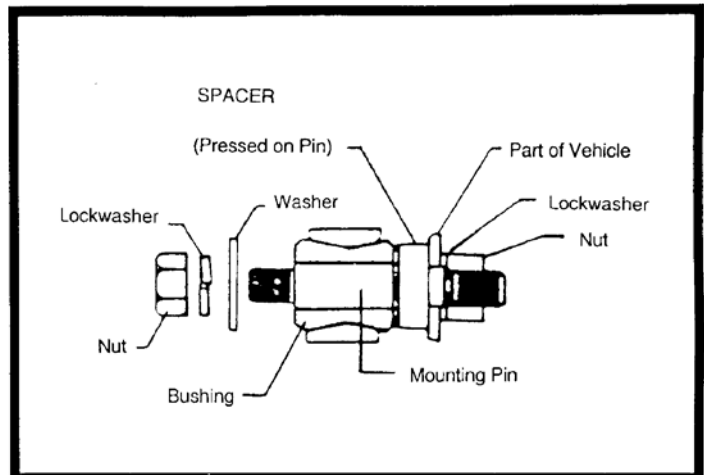

102 S. Michigan Avenue • Coldwater, MI 49036  
517-279-2135 • [www.bds-suspension.com](http://www.bds-suspension.com)

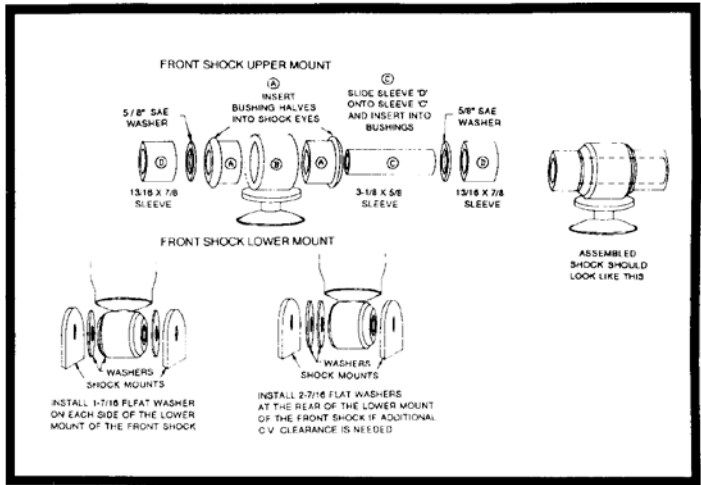
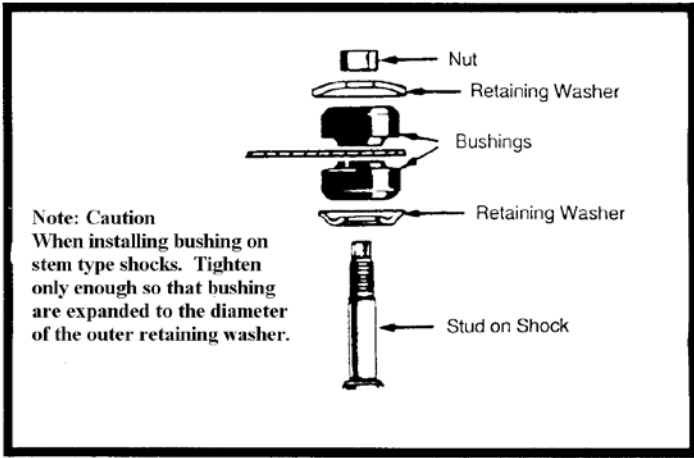

CHEV. S-SERIES W/LIFT

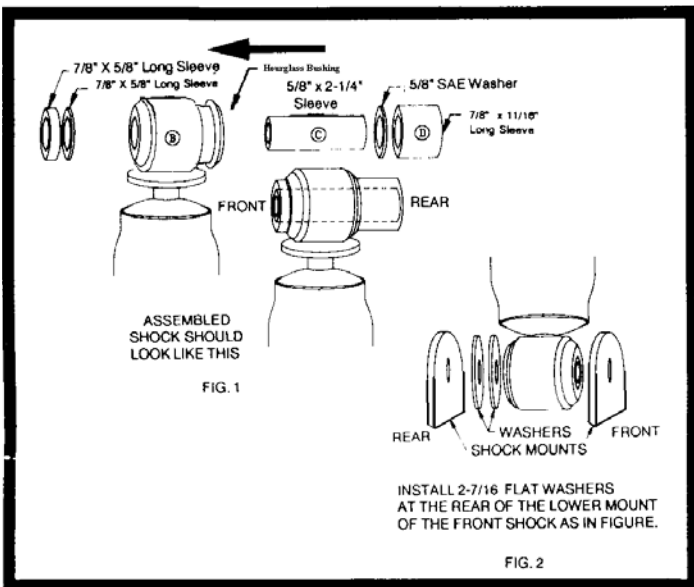
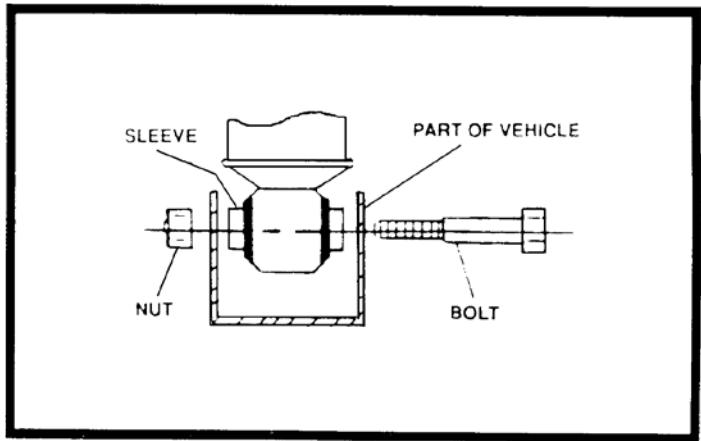
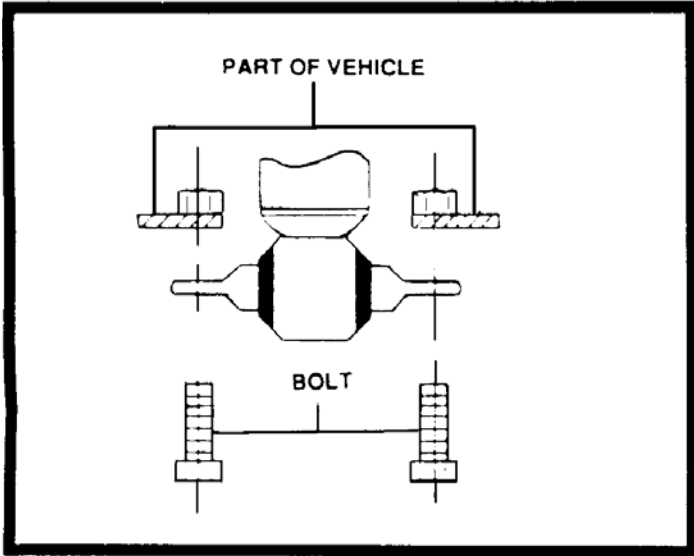

FULL-SIZE CHEV. W/LIFT 88-UP MODELS

