



Bestop

Installation Instructions

For: Suzuki Samurai, All Years
Part Number: 51761



Patent Pending

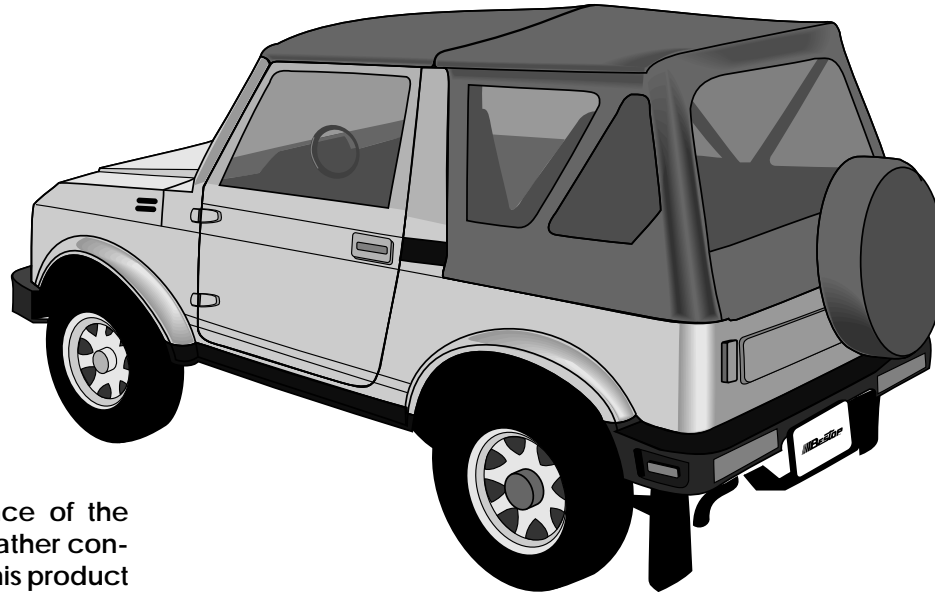

WARNING

This product is designed to enhance the appearance of the vehicle and to shield the occupants from ordinary weather conditions. Do not rely, in any way, on the components of this product to contain occupants within the vehicle, or to protect against injury or death in the event of an accident. This top will not protect the occupants from falling objects. Never operate vehicle in excess of manufacturer's specifications.

WEAR SEAT BELTS AT ALL TIMES.

Read and follow, precisely, all installation instructions provided when installing top. Failure to do so may result in a poor fitting top and could place occupants of the vehicle in a potentially dangerous situation.

Congratulations on your purchasing decision. Bestop designed this Convertible Top to give you years of dependability and performance with proper care. If you encounter any problems during the installation of your Convertible Top, or at any later date, please contact your authorized Bestop dealer or call our Consumer Response Department, Monday - Friday 8AM - 4:30PM (MST) at 1-800-346-3910 or (303) 465-1755 in Colorado.

Installation Tips

Before you begin installing this top assembly, read all instructions thoroughly. Below are a few tips to make this installation easier.

For a smooth fit:

For ease in installation, the top should be installed at temperatures above 72° F. Below this temperature, the top may contract an inch or more, making it difficult to fit to the vehicle.

It is normal for a top to contract and wrinkle when stored in the shipping carton and there may be indentations in the windows. Within a few days of exposure to sunlight, after the installation, the top will relax and the wrinkles will disappear.

Parts List and Hardware Identification



Front Deck, Qty - 1



Sport Bar Retainer, Qty - 1,
Part Number 261.36

20" x 1" Adhesive Hook Strip,
Qty - 1, Part Number 14.71

Plastic Strip, Qty - 1

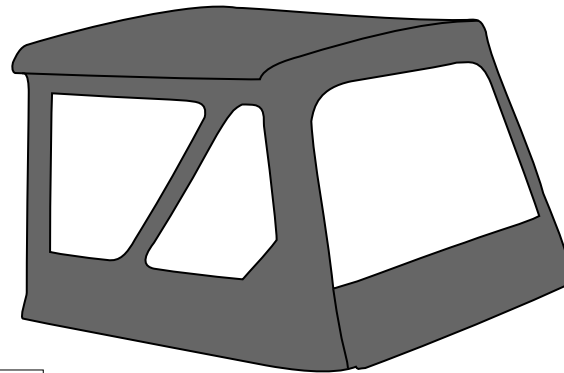

Rear Deck, Qty - 1

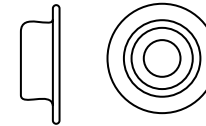

Bow Stud, Qty - 5,
Part Number 9.68



6 Sheet Metal Screw,
Qty - 5, Part Number 9.69



10-24 Truss Head Phillips Screw,
Qty - 2, Part Number 243.77



#10-32 x 1/2 Thread
Forming Screw, Qty - 5,
Part Number 262.04



10-24 Nut, Qty - 2,
Part Number 195.93

Step One

Remove the old top and orient the Sport Bar Retainer on the vehicle. Center the dimples in the retainer over the two bolts in the sport bar. Mark the locations of the three holes in the retainer on the Sport Bar Pad. Draw 1" diameter circles, centered over the hole locations on the Sport Bar Pad. Unzip the Sport Bar Pad and slide the plastic sheet in the parts kit between the Sport Bar and the Sport Bar Pad to protect the paint. Cut out the circular openings. Remove the plastic sheet. If there is foam under the Sport Bar Pad, all foam must be removed from underneath the retainer. Reposition the retainer over the sport bar and mark the positions where the 5 holes are located on the retainer. Center punch and drill a 5/32 inch hole at each location. Install the Sport Bar Retainer using five #10-32 x 1/2 Thread Forming Screws.

Tip: Using talc or baby powder on the plastic strip will make it easier to slip it in and out under the Sport Bar Pad.

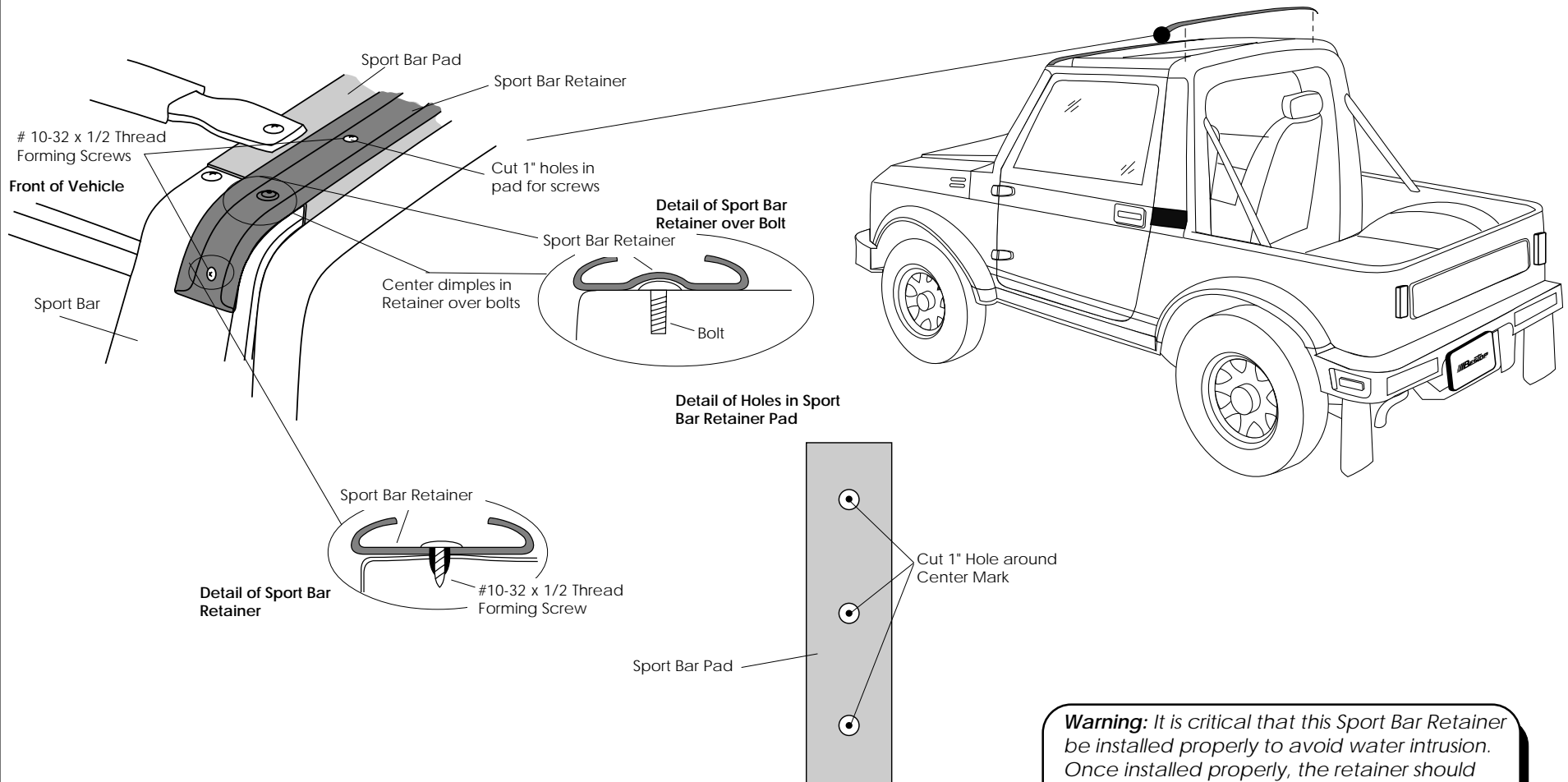

Warning: It is critical that this Sport Bar Retainer be installed properly to avoid water intrusion. Once installed properly, the retainer should never be removed.

Step Two

Orient the Front Deck with the two snaps toward the front of the vehicle. Drape it between the windshield and the sport bar. Open the hook and loop flaps over the doors. Snap the front snaps to the vehicle. Center the plastic strip and slip only the plastic into the channel along the top of the windshield.

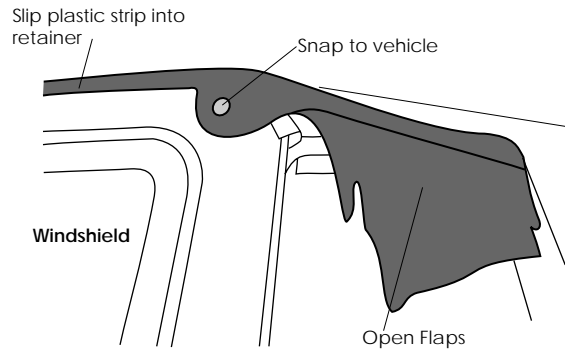

Step Four

Wrap flaps around door frames and attach hook strips to loop strips.

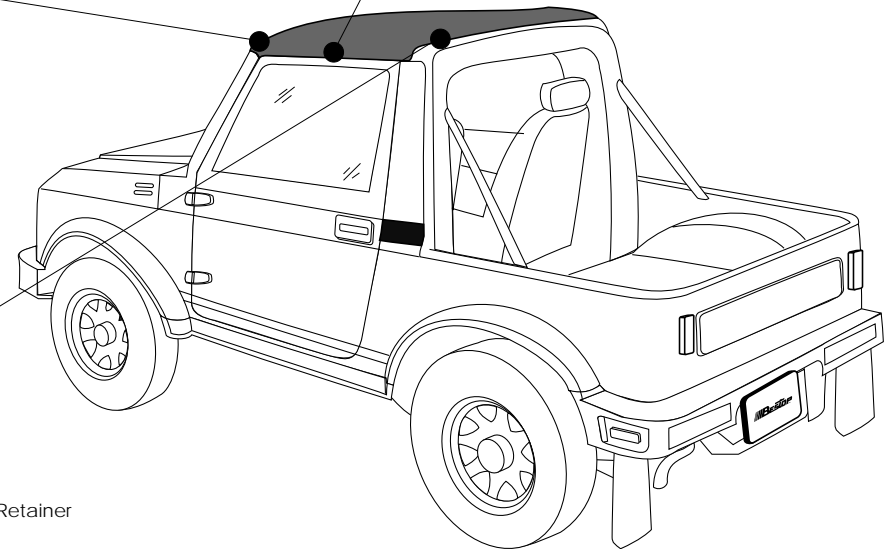
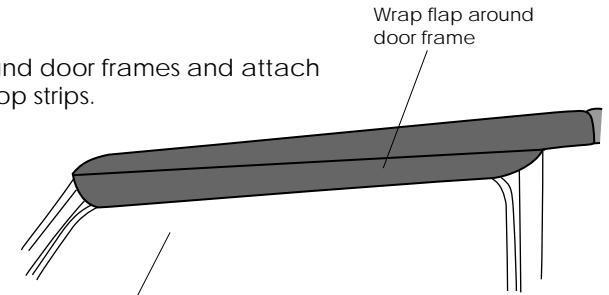

Step Three

Start in the center and work the plastic in the rear of the Front Deck into the front part of the Sport Bar Retainer.

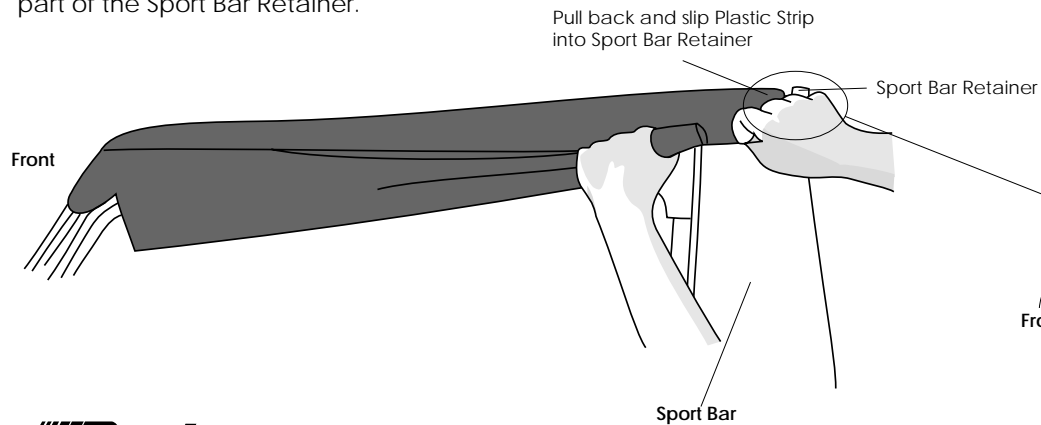

Detail of Fabric into Sport Bar Retainer

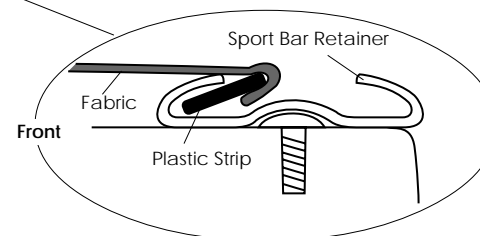

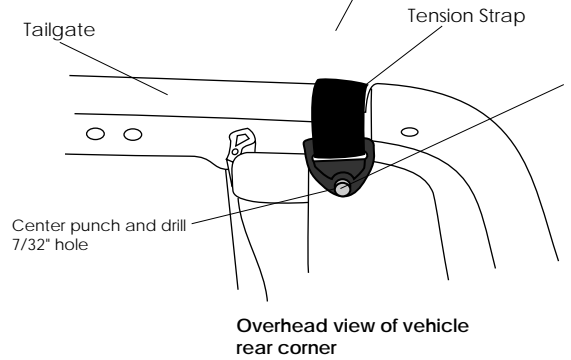
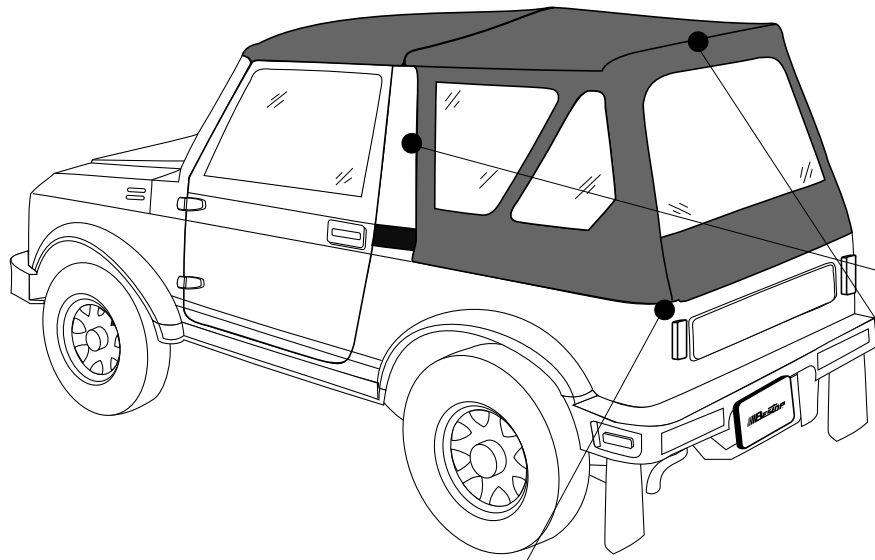

Use a #10-24 x 3/4" Truss Head
Phillips Screw and #10-24 Locknut

Step Six

Orient the Rear Deck on the vehicle. Slide the front edges of the side panels into the channel on the rear of the Sport Bar. Fasten the first body snap on both sides of the vehicle.

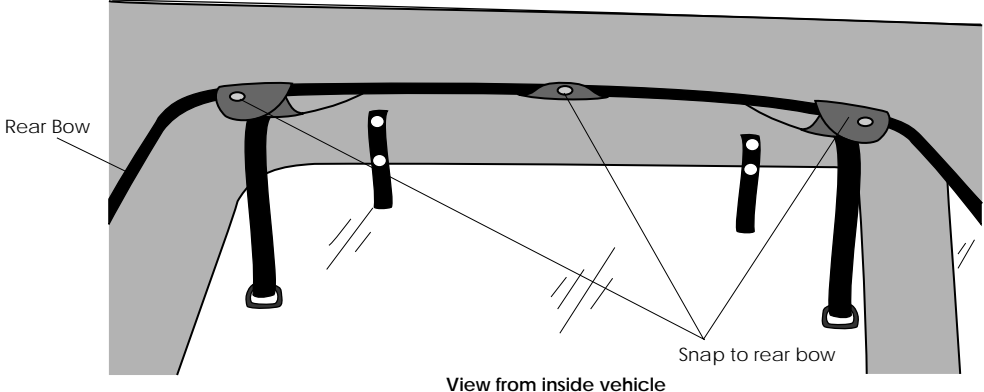
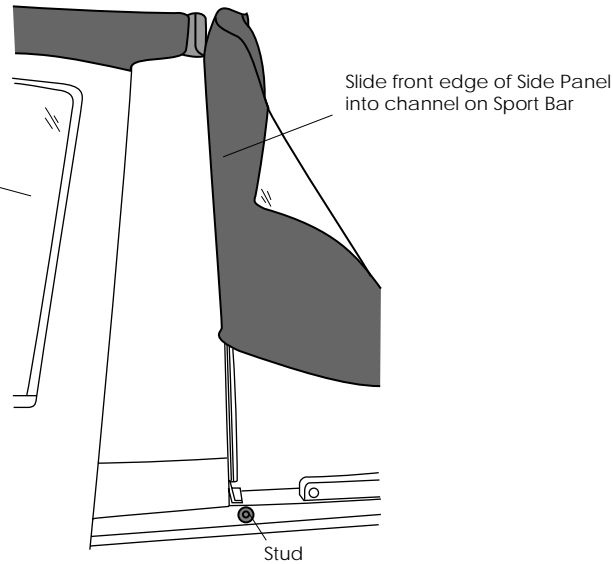

Step Five

Optional
If the Tension Straps are missing from your vehicle, install the straps included with your top. Center punch and drill 7/32 inch holes on each side of the tailgate, above the existing bolt. Install each Tension Straps with a #10-24 x 3/4" Truss Head Phillips Screw and a #10-24 Locknut. Install the Tension Strap with the hook and loop fasteners facing the outside of the vehicle.

Step Seven

Snap the top to the rear bow. The center snap flap will wrap around the bow from behind and the two outer snap flaps will wrap around the bow from the front.



51761 5

Rev. B 1298

Step Nine

Collapse the rear bow by pushing it forward. Insert the plastic strip on the front edge of the Rear Deck into the Sport Bar Channel.

Collapse Rear Bow Forward

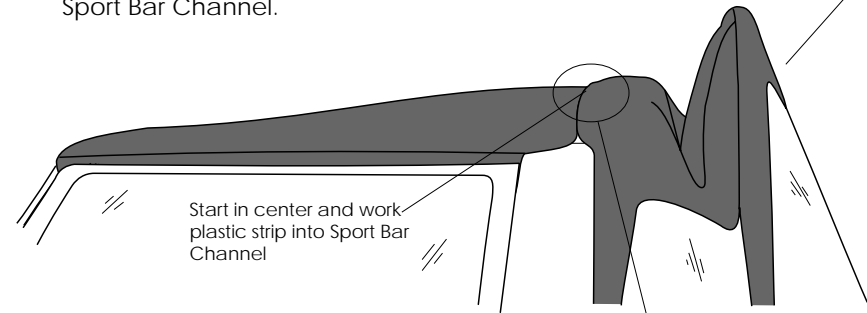

Detail of Fabric into Sport Bar Retainer

Sport Bar Retainer

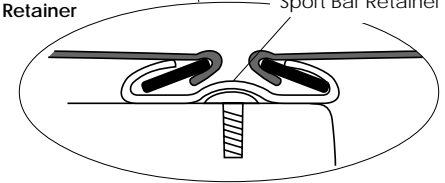

Step Eight

Make sure that the strap sewn into the rear of the top is behind the rear bow.

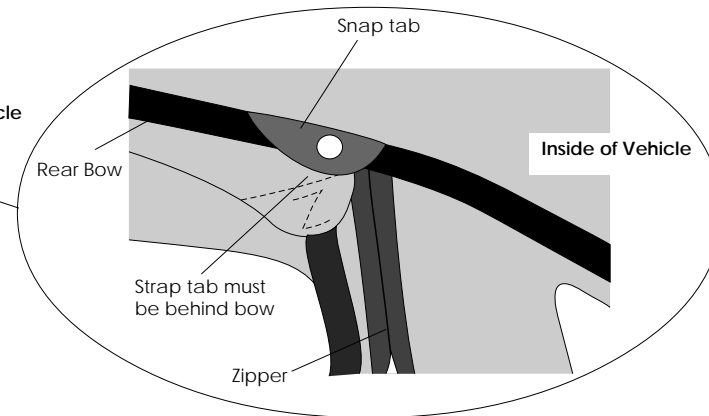
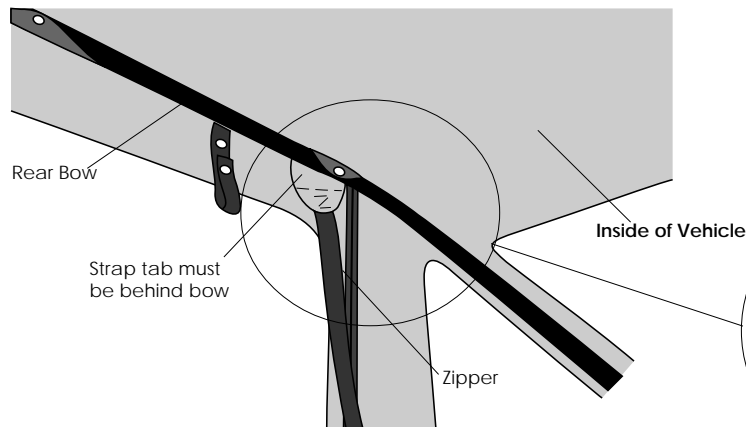

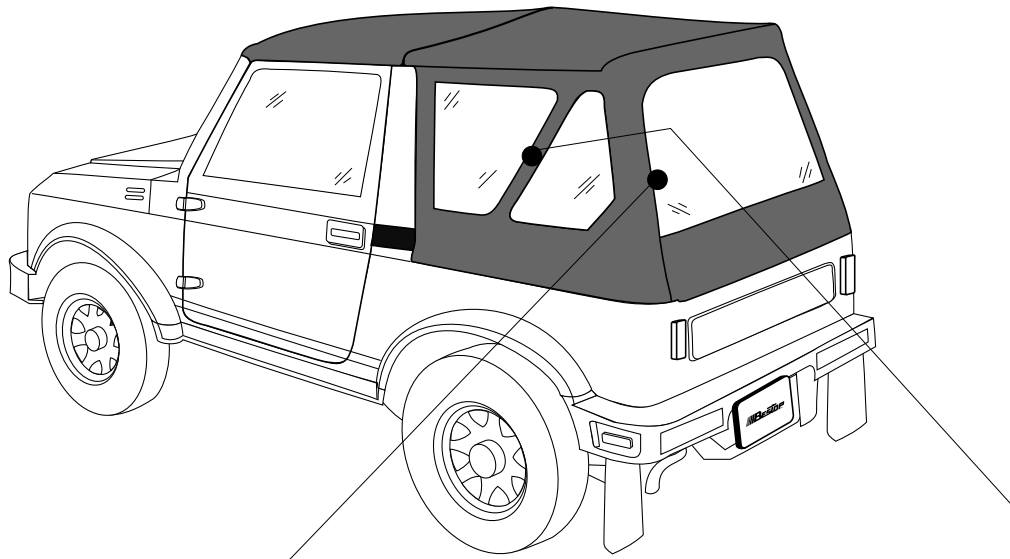

Step Eleven

Snap the snaps on the bottom of the side panels, from front to back.

Step Twelve

Inside the top, wrap the hook and loop sewn to the inside of the side panel, around the Rear Bow. Trim the excess length off the strips if necessary.

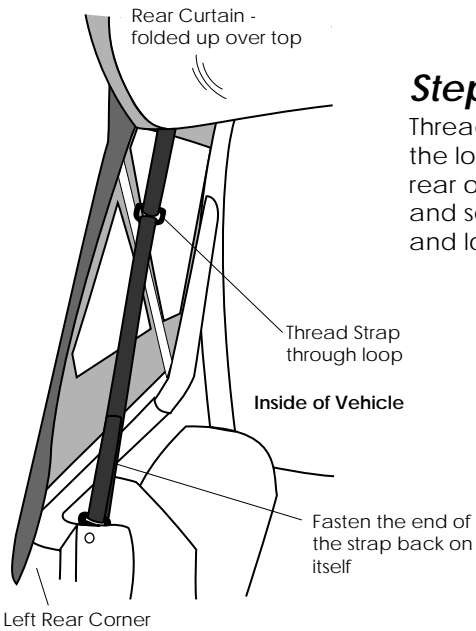

Step Ten

Thread the Tension Strap through the loop on the strap sewn into the rear of the top. Pull the strap tight and secure it in place with the hook and loop sewn to the strap.

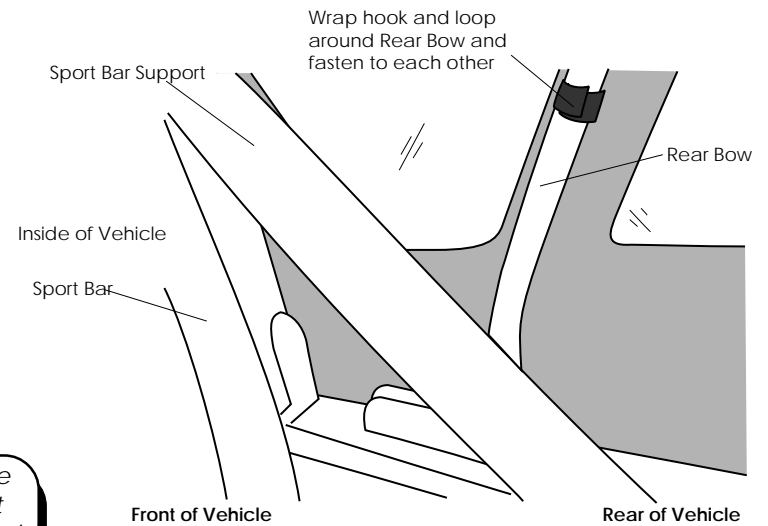

Note: Pull the strap tight. **Do not** put excessive downward pressure on this rear strap. It is not designed to pull the bow assembly downward.

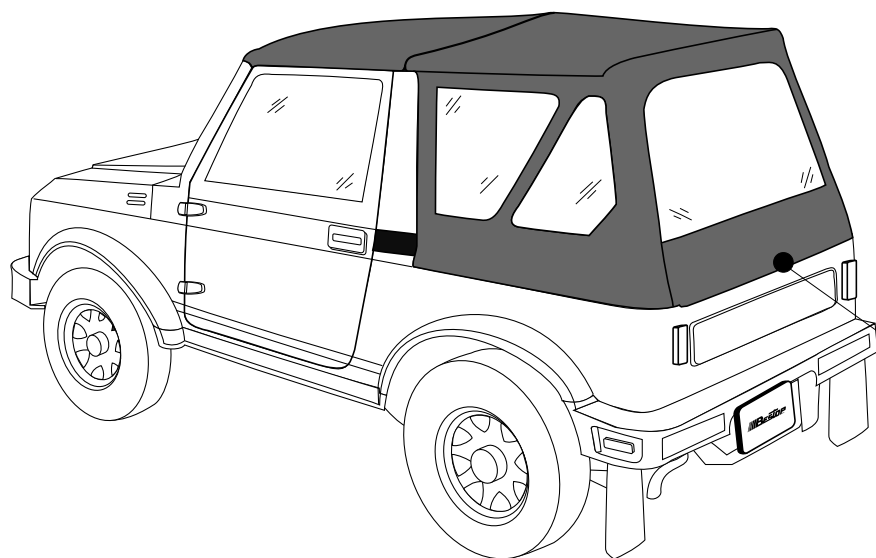

Step Thirteen

Optional

If your vehicle does not have adhesive hook strip on the tailgate, you will need to install it. Cut the adhesive hook into two 8" pieces and one 3" piece. Install the adhesive hook on the tailgate to match the loop sewn into the bottom of the rear curtain.

Hook and Loop Installation

The Adhesive Hook Strip in the parts kit fastens to the loop strip sewn into the Rear Curtain.

Use a 50/50 solution of alcohol and water to clean the locations for the adhesive Hook Strip. Be sure to remove all dirt, silicone sealants, wax, and any other substances which might prevent the adhesive from sticking to the paint.

Note: Do not attempt to apply the adhesive hook in temperatures of less than 60° F. The adhesive backing will fully set within 72 hours of application. You may install the Top after about one hour, but you should avoid unnecessary fastening and unfastening of the cover for 72 hours.

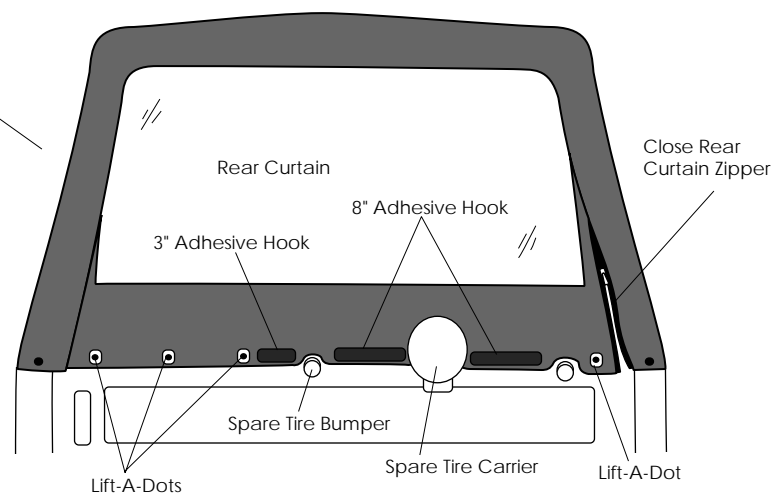

Step Fourteen

Close the Rear Curtain Zipper and fasten the Lift-A-Dots on the Rear Curtain to the studs on the vehicle.

**To Remove the Front Deck with
the Rear Deck in place:**

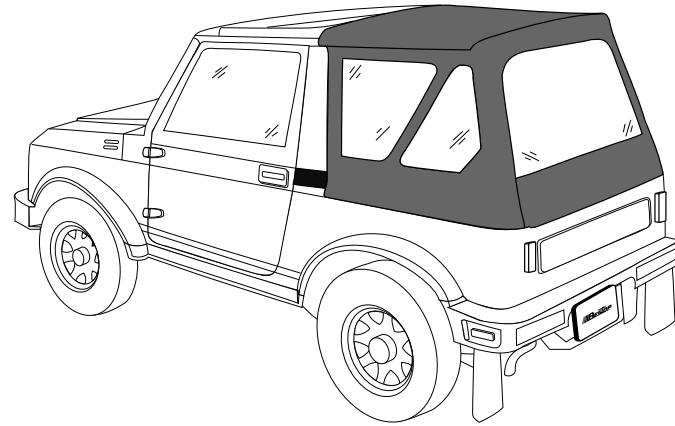

Step One

Unsnap the front snaps and unfasten the Hook and Loop above the doors.

Unsnap front snaps

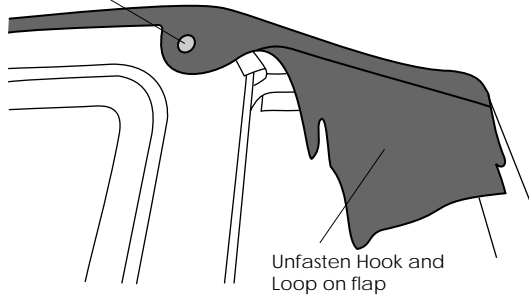

Unfasten Hook and Loop on flap

Step Two

Pull forward on the front fabric and pull the plastic strip on the front of the Front Deck out of the Windshield Retainer. Then pull the plastic strip at the rear of the deck out of the Sport Bar Retainer.

Release front plastic strip first

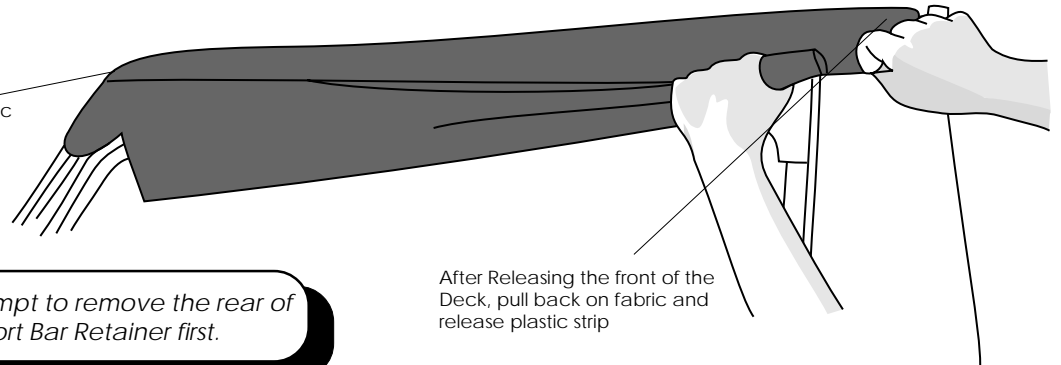

After Releasing the front of the Deck, pull back on fabric and release plastic strip

Warning: Do not attempt to remove the rear of the deck from the Sport Bar Retainer first.

To Remove the Rear Deck with the Front Deck in place:

Warning: If not using rear deck, make sure Rear Bow is completely collapsed

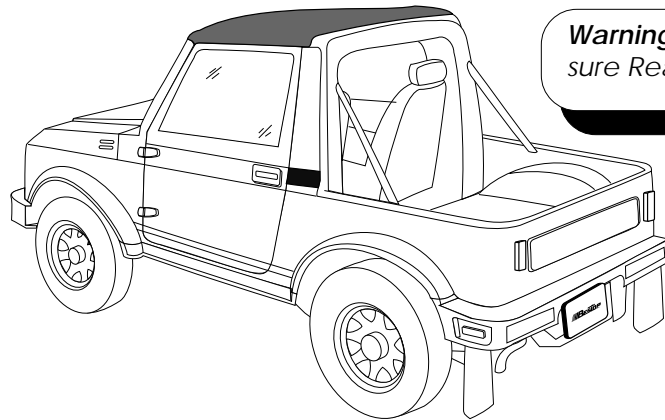

Step One

Unsnap the sides and rear and unfasten the Hook and Loop on the Rear Curtain and around the bow.

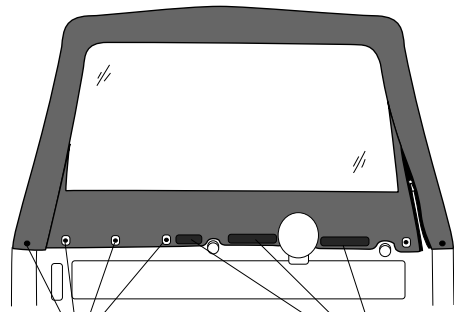

Unfasten rear and sides

Release Hook and Loop

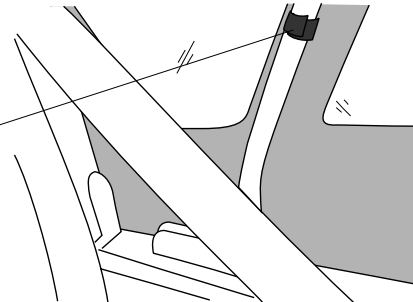

Step Two

Release the Tension Straps.

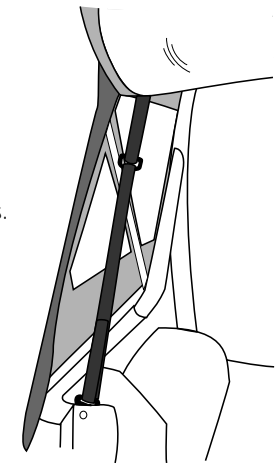

Step Three

Collapse the Rear Bow.

Step Four

Slide the front of the sides up in the channel to release the plastic strip on top. Then slip the sides out of the channel.

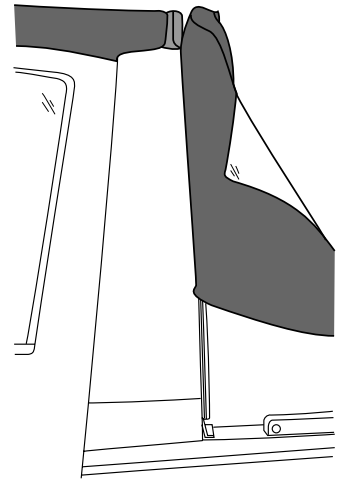

Care and Maintenance of your Bestop Top

Your top is made of the finest materials available. To keep it looking new and for the maximum possible wear, it will need periodic cleaning and maintenance.

Washing: The top fabric should be washed often using soap, warm water and a soft bristle brush. Rinse with clear water to remove all traces of soap.

Windows: Keep windows clean to avoid scratching. DO NOT use a brush on the windows! Wash with a watersoaked cloth or sponge and a mild dishwashing detergent. NEVER WIPE THE WINDOWS WHEN THEY ARE DRY. Be careful when cleaning snow or frost from the vinyl windows since they are easily scratched and may crack at low temperatures. DO NOT roll the sides or rear window in cold weather. The windows become stiff and will crack.

Zippers: Keeping the zipper cleaned and lubricated with a silicone lubricant will help prevent damage and keep the zippers in a smooth working condition. If a zipper opens behind the slider, the slider may have been spread apart. This problem can usually be repaired by using an ordinary pair of pliers to bring the sides back into parallel. Return slider to the normal Open position.

Squeeze lightly at first and test the zipper. If the zipper continues to remain open squeeze more firmly with the pliers and try the zipper again. Repeat this procedure until the zipper operates correctly.

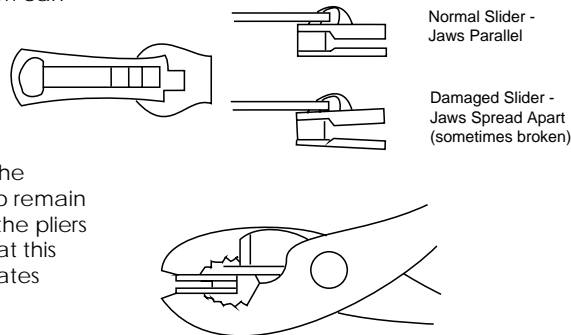

Water: Seeping through at the seams may be stopped by applying 3-M Scotchgard® on the inside of the seams. Rips in the fabric may be repaired with Bondex® iron on patches. Iron the patches to the inside of the top, carefully following the Bondex® instructions.

Snaps: Keep snaps cleaned and lubricated with silicone to help prevent snaps from sticking to the studs. If a snap does become stuck to a stud, use a screwdriver and GENTLY pry apart to prevent permanent damage to the snap or the top fabric.

LIMITED WARRANTY

We warrant our product to be free from defects in material and workmanship, for the terms specified below, provided there has been normal use and proper maintenance. This warranty applies to the original purchaser only. All remedies under this warranty are limited to the repair or replacement of any item or items found by the factory to be defective within the time period specified.

If you have a warranty claim, first you must call our factory at the number below for instructions. You must retain proof of purchase and submit a copy with any items returned for warranty work. Upon completion of warranty work, if any, we will return the repaired or replaced item or items to you freight prepaid. Damage to our products caused by accidents, fire, vandalism, negligence, misinstallation, misuse, Acts of God, or by defective parts not manufactured by us, is not covered under this warranty.

THE WARRANTY TIME PERIOD IS AS FOLLOWS: ALL "SOFT GOODS" MANUFACTURED BY OUR COMPANY (USING PRIMARILY VINYL, PLASTICS, AND/OR FOAM): ONE YEAR FROM DATE OF PURCHASE.

ANY IMPLIED WARRANTIES OF MERCHANTABILITY AND/OR FITNESS FOR A PARTICULAR PURPOSE CREATED HEREBY ARE LIMITED IN DURATION TO THE SAME DURATION AND SCOPE AS THE EXPRESS WRITTEN WARRANTY. OUR COMPANY SHALL NOT BE LIABLE FOR ANY INCIDENTAL OR CONSEQUENTIAL DAMAGE.

Some states do not allow limitations on how long an implied warranty lasts, or the exclusion or limitation of incidental or consequential damages, so the above limitations or exclusions may not apply to you.

This warranty gives you specific legal rights, and you may also have other rights which vary from state to state.

For further information or request for warranty work, please contact:

Bestop Inc.
Customer Service
(800)346-3910
(303)465-1755

