

#013400, #013600

Installation Instructions

Front & Rear Kit

Ford Ranger & Bronco II



READ AND UNDERSTAND ALL INSTRUCTIONS AND WARNINGS PRIOR TO INSTALLATION OF SYSTEM AND OPERATION OF VEHICLE.

SAFETY WARNING

BDS Suspension Co. recommends this system be installed by a professional technician. In addition to these instructions, professional knowledge of disassembly/ reassembly procedures and post installation checks must be known.

PRODUCT SAFETY WARNING

Certain BDS Suspension products are intended to improve off-road performance. Modifying your vehicle for off-road use may result in the vehicle handling differently than a factory equipped vehicle. Extreme care must be used to prevent loss of control or vehicle rollover. Failure to drive your modified vehicle safely may result in serious injury or death. BDS Suspension Co. does not recommend the combined use of suspension lifts, body lifts, or other lifting devices.

You should never operate your modified vehicle under the influence of alcohol or drugs. Always drive your modified vehicle at reduced speeds to ensure your ability to control your vehicle under all driving conditions. Always wear your seat belt.

PRE-INSTALLATION NOTES

1. Special literature required: OE Service Manual for model/year of vehicle. Refer to manual for proper disassembly/reassembly procedures of OE and related components.
2. Adhere to recommendations when replacement fasteners, retainers and keepers are called out in the OE manual.
3. Larger rim and tire combinations may increase leverage on suspension, steering, and related components. When selecting combinations larger than OE, consider the additional stress you could be inducing on the OE and related components.

4. Post suspension system vehicles may experience drive line vibrations. Angles may require tuning, slider on shaft may require replacement, shafts may need to be lengthened or trued, and U-joints may need to be replaced.
5. Secure and properly block vehicle prior to installation of BDS Suspension components. Always wear safety glasses when using power tools.
6. If installation is to be performed without a hoist, BDS Suspension Co. recommends rear alterations first.
7. Due to payload options and initial ride height variances, the amount of lift is a base figure. Final ride height dimensions may vary in accordance to original vehicle attitude. Always measure the attitude prior to beginning installation.

POST-INSTALLATION WARNINGS

1. Check all fasteners for proper torque. Check to ensure for adequate clearance between all rotating, mobile, fixed, and heated members. Verify clearance between exhaust and brake lines, fuel lines, fuel tank, floor boards and wiring harness. Check steering gear for clearance. Test and inspect brake system.
2. Perform steering sweep to ensure front brake hoses have adequate slack and do not contact any rotating, mobile or heated members. Inspect rear brake hoses at full extension for adequate slack. Failure to perform hose check/ replacement may result in component failure. Longer replacement hoses, if needed can be purchased from a local parts supplier.
3. Perform head light check and adjustment.
4. Re-torque all fasteners after 500 miles. Always inspect fasteners and components during routine servicing.

102 S. Michigan Avenue • Coldwater, MI 49036
517-279-2135 • www.bds-suspension.com

PARTS LIST

FRONT PARTS LIST

Qty	Description
2	Radius Arm Drop Brackets (RH/LH)
16	7/16 x 1-1/4" Bolt
4	7/16 x 1-1/2" Bolt
20	7-16" Torque Nut
40	7/16" Flat Washers
2	Axle Pivot Brackets (RH/LH)
2	Anti-Sway Bar Extensions (LH/RH)
12	3/8 x 1" Bolt
12	3/8" Torque Nuts
24	3/8" Flatwashers
2	Bump Stop Extension
1	Pitman Arm

REAR PARTS LIST

Qty	Description
2	2" Lift Blocks (013400 only)
2	4" Lift Blocks (013600 only)
2	Add-A-Leafs
2	3/8" Center Pin
2	3/8" Nut
2	5/8 x .032 x 1/2" Sleeve
4	1/2 x 2-3/4 x 12-1/2" U-Bolt (013400 only)
4	1/2 x 2-3/4 x 14" U-Bolt (013600 only)
8	1/2" Fine High Nut
8	1/2" Flatwashers
1	Rear Brake Line "Z" Drop Brkt
1	3/8" x 1" Bolt
1	3/8" Nut
2	3/8" Flatwasher

INSTALLATION INSTRUCTIONS

1. Safely raise the vehicle and support with jack stands.
2. Remove tires and wheels.
3. Place a floor jack under each axle for support and safety.
4. Remove the stock shock absorbers.
5. Remove the stock radius arm drop brackets from the frame rail only. Do not detach the radius arm bracket from the radius arm. The stock rivets can be removed using an air chisel. Do not use a torch! The pressurized fuel system is located inside the driver's side frame rail. Remove additional OE bolts. (Fig. 1)

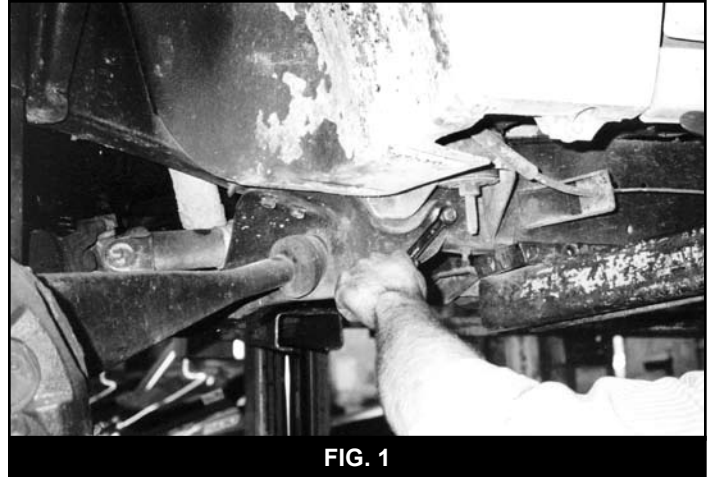

FIG. 1

6. Install BDS radius arm drop brackets. It may be necessary to remove the bracket around the fuel system in order to gain space for access to the bolt holes. Install the BDS drop brackets with 6 - 7/16 x 1-1/4. Re-use two OE bolts per bracket with the OE dual nut bracket. When brackets are in place, torque the fasteners to 60 ft.lbs. (Fig. 2)

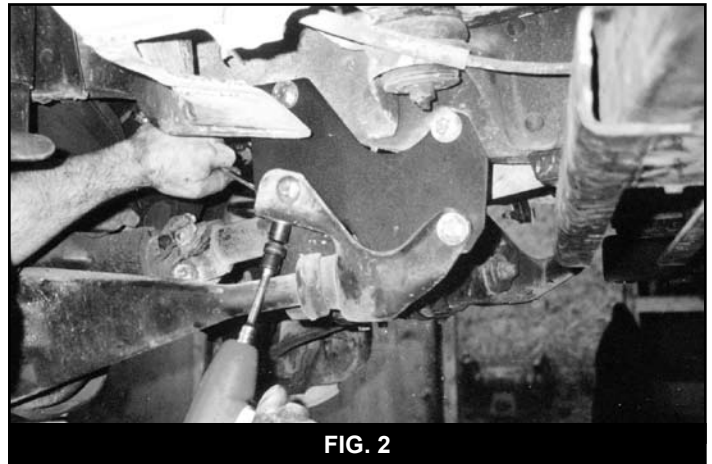

FIG. 2

7. Remove stock coil springs by removing the bottom retaining nut and washer. Once the bottom nut is removed, remove the coil by turning the coil out of the top spring tower. (Fig. 3)

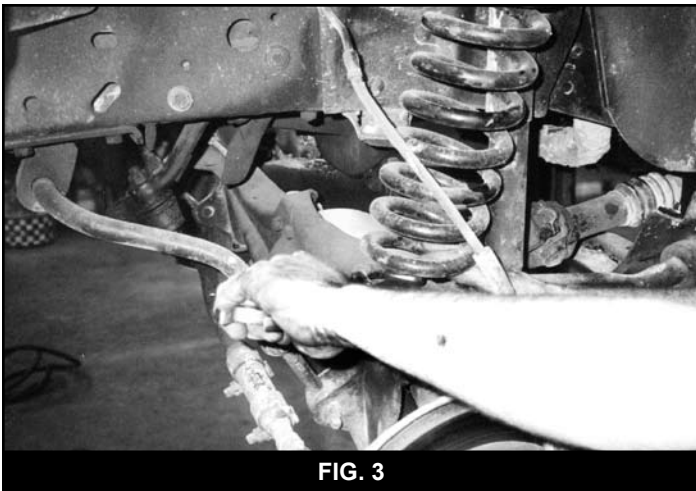

FIG. 3

8. Remove the existing OE bump stops. Attach each bump stop drop bracket to the frame with 1 -3/8 x 1" bolt, nut and washers. Attach the bump stop to the drop bracket using the OE stud. (Fig. 4)

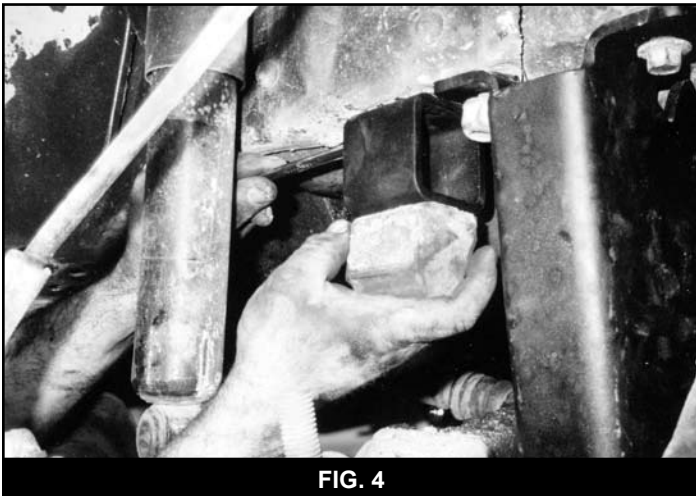

FIG. 4

9. Remove the existing driver's side axle pivot bracket. **Note: Located on the passenger side.** Remove pivot bolt and the five upper bolts and remove the bracket. (Fig. 5)

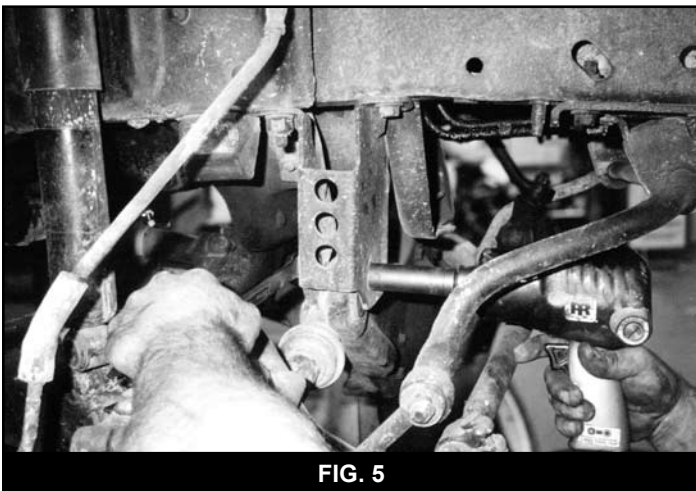

FIG. 5

10. Install new BDS axle pivot bracket using stock bolts, and torque to 65 ft.lbs.

11. Remove the existing passenger's side axle pivot bracket **Note: Located on the driver's side.** The stock axle pivot bracket is located in front of and beneath the oil pan. The bracket is held in place with four rivets that can be removed with an air chisel, drill or grinder. (Fig. 6)

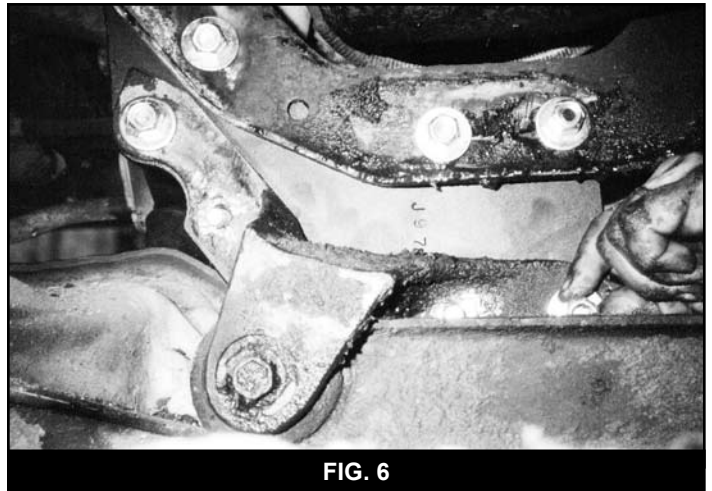

FIG. 6

12. Install the BDS axle pivot drop bracket on the front side of the motor frame support between the frame support and the existing pivot bracket. Attach the stock pivot bracket to the BDS drop bracket using the longer 7/16 x 1-1/2" bolts (Qty 4). Attach the BDS bracket to the frame support using 7/16 x 1-1/4" bolts (Qty 4), locknuts, and flatwashers. After all fasteners are in place you can torque the fasteners to 60 ft.lbs.
13. Brake Line Drop- Driver's Side: Remove the brake line from the frame clip in the upper shock tower, which is the line off of the master cylinder. (Fig. 7)

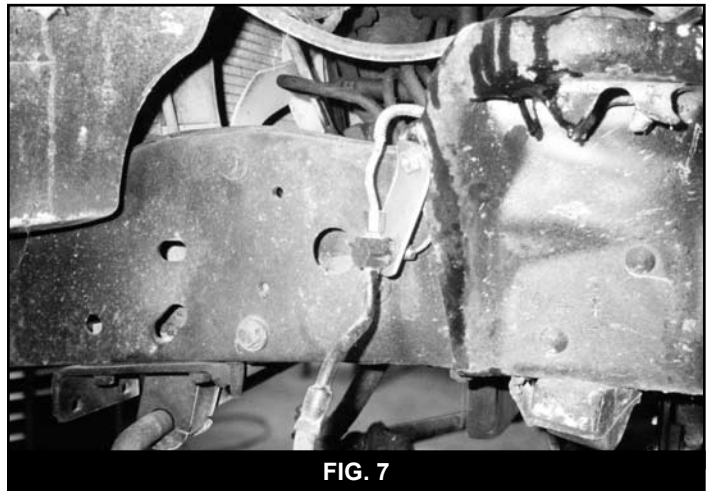

FIG. 7

14. Remove master cylinder brake line from rear of brake hose connection at coil spring tower. Be sure to use a vacuum cap on the brake line to minimize fluid loss.
15. Remove the clip from the hose connection.
16. Install new BDS brake line drop bracket into the existing hole in the spring tower using a 3/8" x 1" bolt, nut, and washers.
17. Install the brake hose into the lower key slot in the drop bracket. Reinstall the clip and the brake line from the master cylinder. The brake line and drop bracket may need to be reformed for proper clearance.
18. Brake Line Drop- Passenger Side: Repeat steps 13 – 17.

19. **WARNING: The brakes will need to be bled once the installation of the drop brackets is complete.** Turn wheels fully left and right to insure that there is no interference of brake lines and hoses.
20. Support the anti-sway bar with a jack and then disconnect it from the frame. The anti-sway bar is attached with two bolts on each side. Install the BDS anti-sway bar drop brackets using 3/8" x 1" bolts (Qty 4), nuts, and washers. Install the bracket so the "U" channel of the bracket is facing the center of the vehicle and the angle going back toward the bottom of the bracket. Tighten all fasteners after the assembly is complete. (Fig. 8)

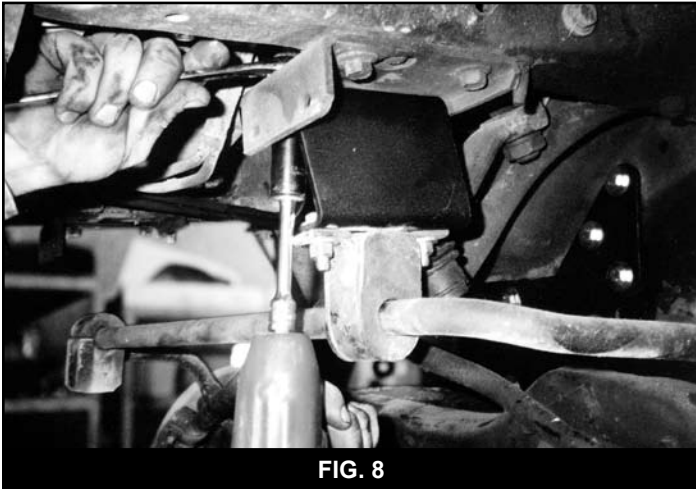

FIG. 8

21. Remove the OE pitman arm using an appropriate puller. Install new BDS pitman arm and torque to 170 ft.lbs. Attach steering linkage to the pitman arm and torque to 45 ft.lbs. Be sure to install new cotter key.
22. Coil spring installation. Place the small end of the new coil on the coil seat and spin the coil into the upper tower. Be sure the spring keeper tabs are bent back into their original position. Tighten the bottom coil retaining nut to 70 ft.lbs. (Fig. 9)

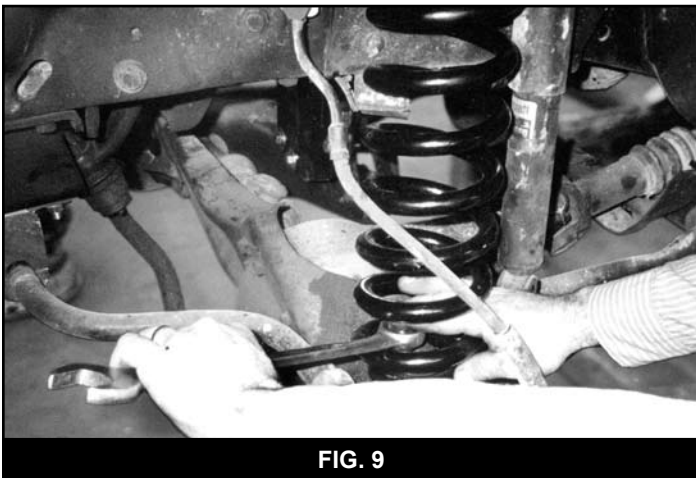

FIG. 9

23. Install the appropriate BDS shocks at this time. Tighten upper stem till bushings start to swell. Lower bolt torque to 40 ft.lbs.

REAR INSTALLATION

1. Place jack stands under the rear axle.
2. Remove the stock shock absorbers.

3. Remove the OE u-bolts at the spring/axle connection.
4. Lower the jack stands to allow for the block installation.
5. Cut the OE rear brake line bracket, bend it down and remove the rear brake line. Bend the bracket back into place and bolt the new "Z" drop bracket in place with a 3/8" fastener. Attach the brake line to the keyslot in the "Z" drop bracket. (Fig. 10)

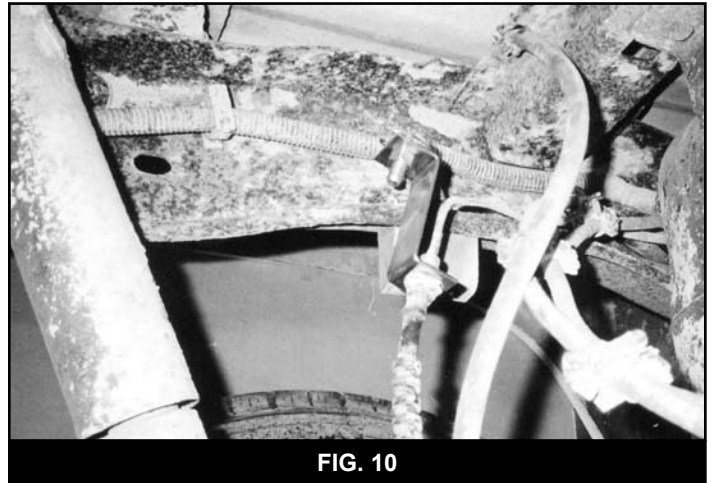

FIG. 10

6. Place the new block between the axle pad and the existing block. The smaller tapered end of the block should face the front of the vehicle. (Fig. 11)

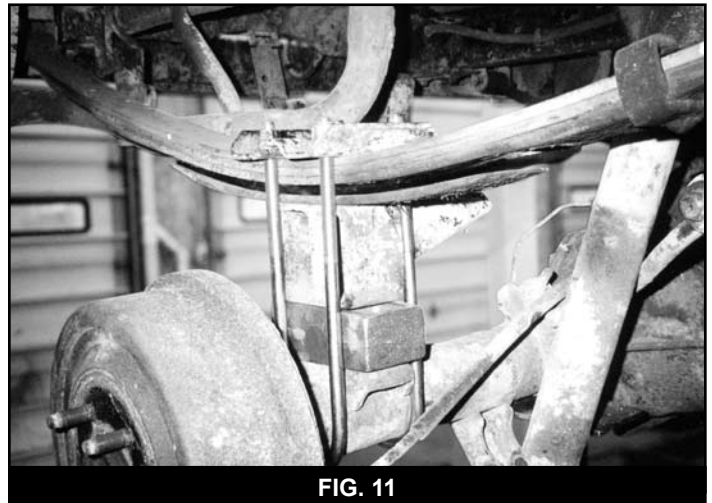

FIG. 11

7. Install add-a-leaf on top of the stock flat overload spring on the bottom of the arched leaf spring.
8. Install new u-bolts with high nuts and washers and torque to 70-85 ft.lbs.
9. Install new BDS shock absorbers. Torque OE bolts to 40 ft.lbs.
10. Check all hardware.
11. Install wheels and tires.
12. Loosen front tie rod adjustment sleeves. Turn sleeves until wheels run straight.
13. Lower vehicle.
14. Tighten adjustment sleeves.
15. The front end must be aligned before driving the vehicle.
16. Check all fasteners after 500 miles.

Shock Absorber Installation Instructions



READ AND UNDERSTAND ALL INSTRUCTIONS AND WARNINGS PRIOR TO INSTALLATION OF SYSTEM AND OPERATION OF VEHICLE.

LIMITED LIFETIME WARRANTY

BDS Suspension Co. warrants to the original retail purchaser that its shock and stabilizer cylinders are free from defects in material and workmanship for so long as they own the vehicle. Excluded from this warranty are the finish of the product and mounting bushings. Defects in material and workmanship do not include such things as dented cylinders or bent rods caused by obvious side impact, rust, worn or deformed bushings. A shock absorber is a wear item and over time will experience diminished damping resistance due to normal component wear. This is not a defect in material or workmanship and is therefore not warrantable.

BDS Suspension's obligation under all warranties is limited to the repair or replacement, at BDS's option, of the defective material. Any cost of removal, installation or reinstallation, freight charges, incidental or consequential damages are expressly excluded from these warranties.

INSTALLATION INSTRUCTIONS

1. **Note: Please read instructions thoroughly before installing shock absorber.**
2. Remove old shock absorber from vehicle. Note any spacers, washers, sleeves or other hardware and note their location. Compare the existing hardware with the supplied hardware. Always use new hardware wherever possible. Due to the variety of applications, you may not use any or all of the hardware supplied. You may need to use some of the original hardware. If any of the original hardware is damaged, corroded, bent or broken it must be replaced.

3. If installing dust boot, do so at this time. **Note: The use of a lubricant like dish soap on the inside of the boot will ease installation.** Make sure the washer at the top of the shock is fully seated in the boot all the way around. Secure the bottom of the boot to the cylinder with a plastic tie strap.
4. Install any required bushings and sleeves in to the shock eyes at this time. Install the shock absorber on the vehicle. Use the appropriate illustration as a frame of reference. Due to the different shock mounts within a vehicle model range, the shock eyes must be built to match the shocks that you removed by using the universal hardware kit included. Choose the sleeve with an I.D. closest to the O.D. of the mounting stud or bolt without binding. Some applications will require some extra effort to install.
5. Check all fasteners for tightness before driving and inspect periodically.

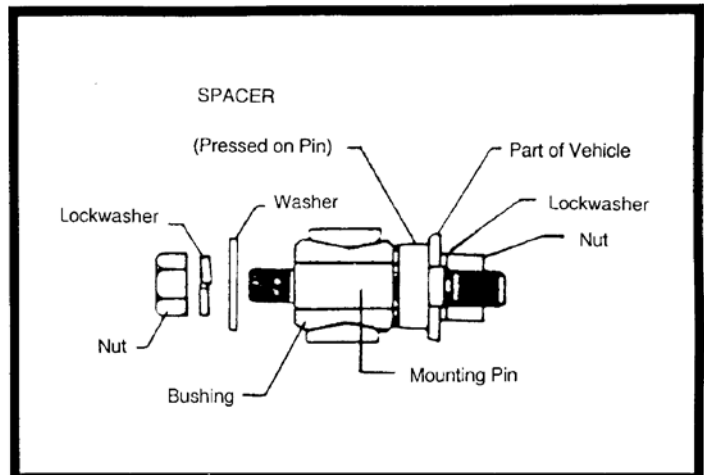

102 S. Michigan Avenue • Coldwater, MI 49036
517-279-2135 • www.bds-suspension.com

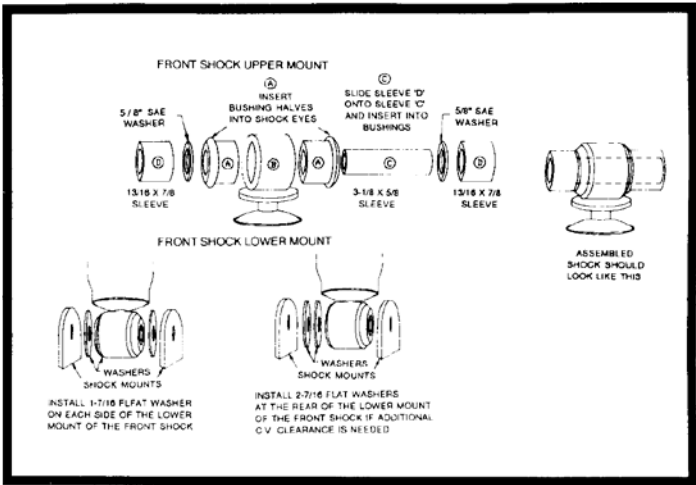
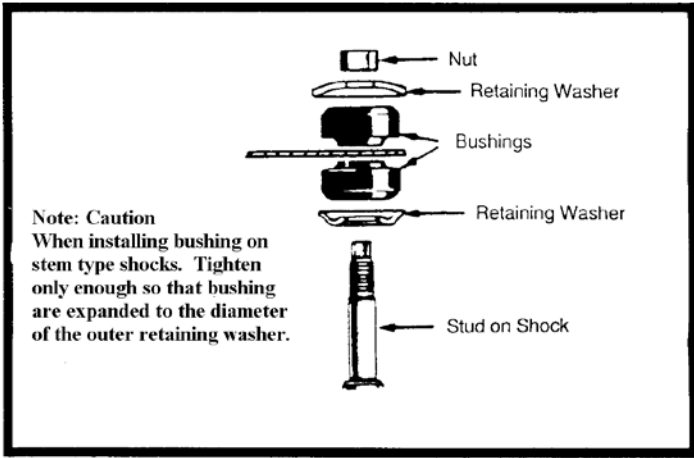

CHEV. S-SERIES W/LIFT

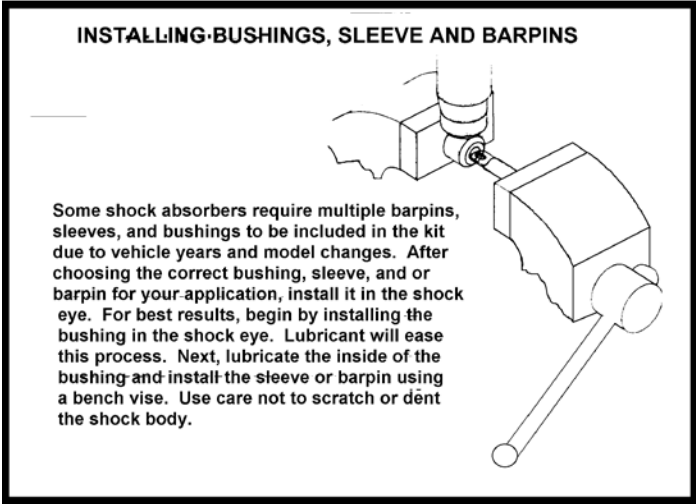
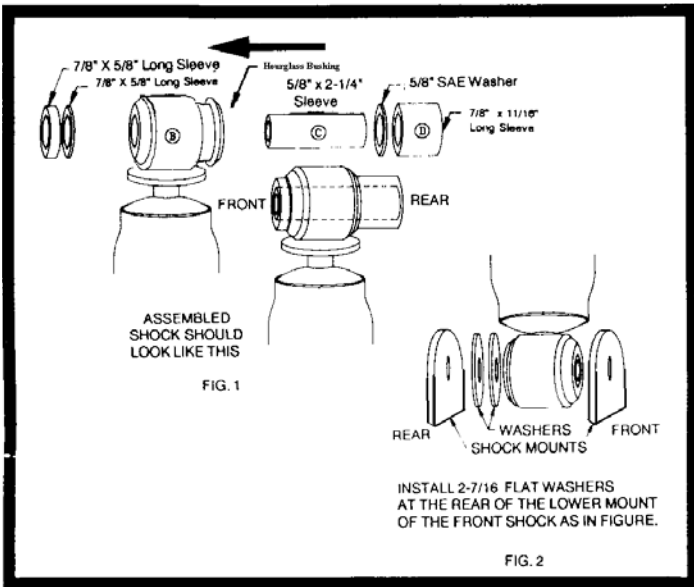
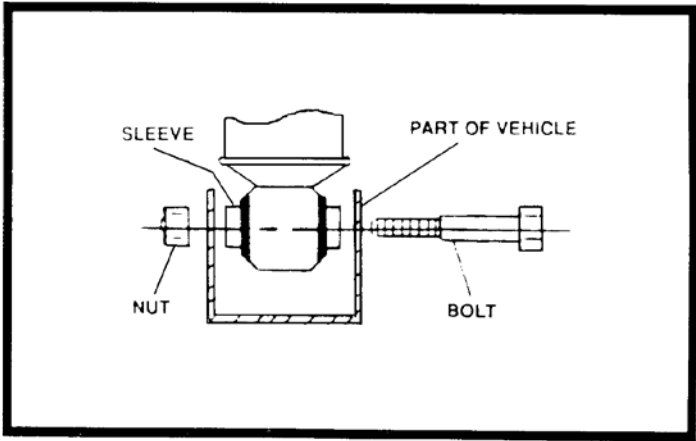
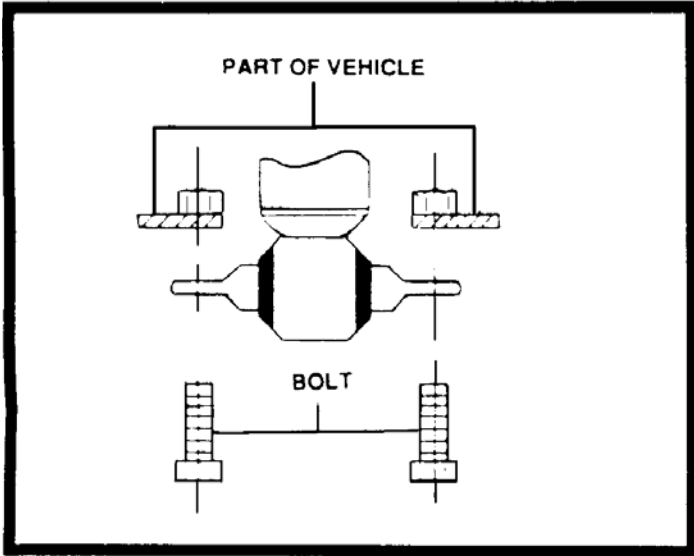

FULL-SIZE CHEV. W/LIFT 88-UP MODELS

Coil Spring

Installation Instructions

READ AND UNDERSTAND ALL INSTRUCTIONS AND WARNINGS PRIOR TO INSTALLATION OF SYSTEM AND OPERATION OF VEHICLE.

SAFETY WARNING

BDS Suspension Co. recommends this system be installed by a professional technician. In addition to these instructions, professional knowledge of disassembly/ reassembly procedures and post installation checks must be known.

PRODUCT SAFETY WARNING

Certain BDS Suspension products are intended to improve off-road performance. Modifying your vehicle for off-road use may result in the vehicle handling differently than a factory equipped vehicle. Extreme care must be used to prevent loss of control or vehicle rollover. Failure to drive your modified vehicle safely may result in serious injury or death. BDS Suspension Co. does not recommend the combined use of suspension lifts, body lifts, or other lifting devices.

You should never operate your modified vehicle under the influence of alcohol or drugs. Always drive your modified vehicle at reduced speeds to ensure your ability to control your vehicle under all driving conditions. Always wear your seat belt.

PRE-INSTALLATION NOTES

1. Special literature required: OE Service Manual for model/year of vehicle. Refer to manual for proper disassembly/reassembly procedures of OE and related components.
2. Adhere to recommendations when replacement fasteners, retainers and keepers are called out in the OE manual.
3. Larger rim and tire combinations may increase leverage on suspension, steering, and related components. When selecting combinations larger than OE, consider the additional stress you could be inducing on the OE and related components.

4. Post suspension system vehicles may experience drive line vibrations. Angles may require tuning, slider on shaft may require replacement, shafts may need to be lengthened or trued, and U-joints may need to be replaced.
5. Secure and properly block vehicle prior to installation of BDS Suspension components. Always wear safety glasses when using power tools.
6. If installation is to be performed without a hoist, BDS Suspension Co. recommends rear alterations first.
7. Due to payload options and initial ride height variances, the amount of lift is a base figure. Final ride height dimensions may vary in accordance to original vehicle attitude. Always measure the attitude prior to beginning installation.

POST-INSTALLATION WARNINGS

1. Check all fasteners for proper torque. Check to ensure for adequate clearance between all rotating, mobile, fixed, and heated members. Verify clearance between exhaust and brake lines, fuel lines, fuel tank, floor boards and wiring harness. Check steering gear for clearance. Test and inspect brake system.
2. Perform steering sweep to ensure front brake hoses have adequate slack and do not contact any rotating, mobile or heated members. Inspect rear brake hoses at full extension for adequate slack. Failure to perform hose check/ replacement may result in component failure. Longer replacement hoses, if needed can be purchased from a local parts supplier.
3. Perform head light check and adjustment.
4. Re-torque all fasteners after 500 miles. Always inspect fasteners and components during routine servicing.

INSTALLATION INSTRUCTIONS

1. Place floor jack under the outer ends of both axle halves and evenly raise the vehicle approximately one foot. Place floor jacks under the frame rails approximately 4" behind the radius arm brackets. Ease the vehicle down on to the stands. Continue to lower the vehicle until there is little pressure on the coil springs.
2. Remove the tires.
3. If replacement shocks will be installed, then remove the existing shocks. If the existing shocks are to be reused, then only unbolt the bottom of the shocks.
4. Perform the coil spring replacement one side at a time. **Warning: During the entire installation do not allow the brake line to be pulled taut.** Remove the lower retaining nut and washer. Ease the axle down and away from the coil.

MID SIZE- Unscrew the upper coil end to remove the coil.

FULL SIZE- Remove the upper coil spring retaining clip to remove the spring.

5. Install the BDS Coil. Be sure to center the spring before tightening the lower retaining washer/nut.

MID SIZE- The spring tower prongs will have to be re-formed around the top coil of the spring.

FULL SIZE- Replace the spring retaining clip.

6. Replace or rebolt the shock as necessary.
7. Repeat steps 2 through 6 on the opposite side of the vehicle.
8. Recheck every nut/bolt that has been touched for proper torque.
9. Install tires and lower vehicles to ground.
10. Adjust the headlights as needed.

J-CLIP INSTALLATION

DRIVER'S SIDE VIEW

